

Dealer Update

Steering, Brakes & Suspension

SEMA
2018 ISSUE



EDITION SIXTEEN

WHAT A YEAR IT'S BEEN!

As 2018 comes to a close, we are excited to return to SEMA, for our 15th consecutive year, to raise consumer awareness of the CPP brand and expand our constantly growing product line. This Dealer Update is our biggest ever, bringing you 52 pages of new components we feel would be a great addition to you and your customer's builds. We are also introducing our new dealer team whose goal is to understand your growing business and be available to address all of your needs and concerns throughout the year.

We added numerous shows to our calendar this year, which brought us face-to-face with CPP customers all over the United States! Our 2018 road trips have been pretty epic to say the least! We went all the way up north to Central California, down south to good ol' Fort Worth, Texas, and east to the Midwest shows in Iowa, Ohio, Kentucky and Tennessee. One of the best parts about these road trips was taking our CPP built cars out on the road with us!



Our road warrior, Sadie Ries, along with the guys of CPP, kicked off the year at Good Guys' Del Mar where we sponsored the autocross event. Then, in May, we developed our brand new **Dual-Adjustable Complete Front and Rear Coil-Over systems for 1963-87 Chevy Trucks!** How did we test the quality of this kit? By taking it out on the track at this year's C10 Nationals in Fort Worth, Texas! Just days after the installation of the very first kit, Sadie took Classic Truck Magazine's Week to Wicked 1970 Chevy C10 out on the autocross track and showed the world its corner-carving capability! In June and July, we headed to Good Guys' Iowa and Ohio where we talked to many customers running CPP products on their builds. Our '55 Revive made its



3rd year voyage to Kentucky for the Danchuk Tri-five Nationals, which is always something we look forward to! So many Trifives, so little time! As a true testament to what we do, Sadie drove our 1970 Camaro from Placentia, California to the F-Body Nationals in Memphis, Tennessee (2500 miles!!), put it to the test at the autocross event, drove it to Texas that same weekend (while the wheels were still smokin'!), then took it back out on the autocross track a week later at the Good Guys' Fort Worth event. No trailer was needed, as Sadie drove it back home after our road trip was over. Now that's what we call **"dependable performance!"**

In between all of these shows, we built our 1967 Camaro, dubbed the "Comeback Camaro", as this year's entry for the Super Chevy Muscle Car challenge. With street performance and autocrossing in mind, we installed our new **Pro-Series 6-Piston Front and Rear Big Brake Kit, 500 Series Power Steering Box, new High Clearance Front and Adjustable Rear Sway Bars** and more. Partnering with other proven products in the industry, such as **Viking Performance, American Autowire, Currie Enterprises**, and many others, proves that CPP steering, brakes and suspension products work well with other brands and eliminates the guesswork of fitment on any build. We asked Bondurant School of Driving's professional driver, Canaan O'Connell, to put our Camaro to the test, and boy did he do just that! From the road course, to the slalom, and the 100-yard dash, the Comeback Camaro put on a great performance! We were definitely satisfied with the result!

Along with our own builds, we also made time to connect with our friends at Hot Rod magazine where we took a 1959 Chevy Apache Fleetside, owned by Stabil, and transformed it into a reliable and comfortable shop truck, worthy of the road trip of a lifetime – the Hot Rod Power Tour. We installed our Mustang II Independent Front Suspension with the added upgrades, such as CPP's **11.75" Performance Brakes and Modular Spindles**, along with our new



Scan QR code to check out our *Comeback Camaro on the track* >



Canaan O'Connell put our Comeback Camaro to the test with Sadie Ries at the Texas Motor Speedway

Dual-Adjustable Coil-Over Upgrade for Mustang II applications, and our **Fuel Injection-Ready 22 Gallon Aluminum Tank**. We recently partnered up again with Classic Trucks Magazine to build Long Motor Company's giveaway truck at the 2019 C10 Nationals – a beautiful 1972 Chevy C10. Our goal with these Week to Wicked builds is to show that adding performance to your vehicle does not need to break your bank or take years to complete! If we can do all the installation in one week, you can do it at home! This '72 Chevy C10 is equipped with, tried and true CPP components along with our newest offerings in our Chevy Truck product line. Whoever wins this beauty next year is going to be a very lucky participant!

2018 has given us many wonderful opportunities to connect with our customers and we thank you for always choosing us.

We have BIGGER things lined up for 2019, so stay tuned!

Classic Performance Products, Inc.

BRAKES / MIDNITE SERIES / BRAKE BOOSTER KITS

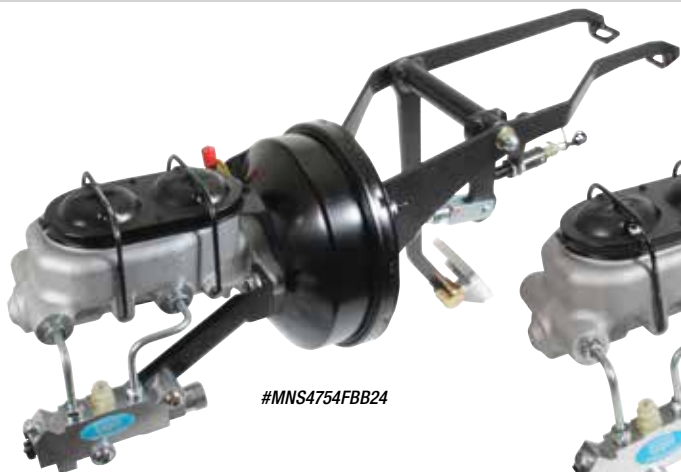

#MNS4754FBB24



#MNS5864BB24

**NEW
MIDNITE BLACK
SHOW FINISH**



#MNS6772BB24



#8DSBMCB2

**SMOOTH
TOP**



NEW!

MIDNITE SERIES BOOSTER COMBO KITS

CPP introduces our newest addition - Midnite Series Booster Combo Kits. Our new booster kits are available for street rods, custom cars as well as vehicle specific application.

KITS FEATURE*

- Vacuum Assisted Brake Booster with a Beautiful Black Finish
- Aluminum Master Cylinder with Black Bails & Cap
- Aluminum Proportioning Valve
- Mounting Brackets, Lines & Hardware for an Easy Install

**AVAILABLE
IN 7", 8", 9",
& 11" SINGLE
OR
7", 8", & 9"
DUAL
BOOSTERS**

PART #	DESCRIPTION	RETAIL	JOBBER	DEALER
FIREWALL MOUNT:				
MNS5559FBB24	1955-59 Chevy Truck, kit	\$299.00	\$263.00	\$210.00
MNS6062BB24	1960-62 Chevy Truck, AT only, kit	\$299.00	\$263.00	\$210.00
MNS6366BB24	1963-66 Chevy Truck, kit	\$299.00	\$263.00	\$210.00
MNS6772BB24	1967-72 Chevy Truck, kit	\$299.00	\$263.00	\$210.00
MNS7387BB24	1973-87 Chevy Truck, kit	\$299.00	\$263.00	\$210.00
MNS4852FBB24	1948-52 Ford Truck, kit	\$299.00	\$269.00	\$210.00
MNS5356FBB24	1953-56 Ford Truck, kit	\$299.00	\$269.00	\$210.00
MNS5760BB24	1957-60 Ford Truck, kit	\$299.00	\$269.00	\$210.00
MNS6466BB24	1964-66 Ford Mustang, kit	\$299.00	\$269.00	\$210.00
MNS4954FBB24	1949-54 Chevy Fullsize, kit	\$299.00	\$263.00	\$210.00
MNS5557BB24	1955-57 Chevy Fullsize, kit	\$299.00	\$263.00	\$210.00
MNS5864BB24	1958-64 Chevy Fullsize, kit	\$299.00	\$263.00	\$210.00
MNS6570BB24	1965-70 Chevy Fullsize, kit	\$299.00	\$263.00	\$210.00
MNS6267BB24	1962-67 Nova, kit	\$299.00	\$275.00	\$210.00
MNS6774BB24	1967-69 Camaro, 1968-74 Nova, kit	\$299.00	\$263.00	\$210.00
MNS7079BB24	1970-79 Camaro, kit	\$299.00	\$263.00	\$210.00
MNS6466CBB24	1964-66 Chevelle, kit	\$299.00	\$263.00	\$210.00
MNS6772CBB24	1967-72 Chevelle, kit	\$299.00	\$263.00	\$210.00
FRAME MOUNT:				
MNS4754BB24	1947-54 Chevy Truck, kit	\$299.00	\$263.00	\$210.00
MNS5559BB24	1955-59 Chevy Truck, kit	\$299.00	\$263.00	\$210.00
MNS4852BB2	1948-52 Ford Truck, kit	\$299.00	\$269.00	\$210.00
MNS5356BB2	1953-56 Ford Truck, kit	\$299.00	\$269.00	\$210.00

MIDNITE SERIES STREET ROD/UNIVERSAL KITS

PART #	DESCRIPTION	RETAIL	JOBBER	DEALER
WITH ALUMINUM MASTER CYLINDER				
MNS7SRB-MC	7" dia. single booster	\$209.00	\$184.00	\$139.00
MNS7DSRB-MC	7" dia. dual booster	\$209.00	\$184.00	\$139.00
MNS8SRB-MC	8" dia. single booster	\$209.00	\$184.00	\$139.00
MNS8DSRB-MC	8" dia. dual booster	\$209.00	\$184.00	\$139.00
WITH SMOOTH TOP MASTER CYLINDER				
7SBMCB1	7" dia. single booster, with adjustable prop valve	\$269.00	\$239.00	\$199.00
7SBMCB2	7" dia. single booster, with adjustable prop valve dist. block	\$299.00	\$267.00	\$210.00
7DSBMCB1	7" dia. dual booster, with adjustable prop valve	\$269.00	\$239.00	\$199.00
7DSBMCB2	7" dia. dual booster, with adjustable prop valve dist. block	\$299.00	\$267.00	\$210.00
8SBMCB1	8" dia. single booster, with adjustable prop valve	\$269.00	\$239.00	\$199.00
8SBMCB2	8" dia. single booster, with adjustable prop valve dist. block	\$299.00	\$267.00	\$210.00
8DSBMCB1	8" dia. dual booster, with adjustable prop valve	\$269.00	\$239.00	\$199.00
8DSBMCB2	8" dia. dual booster, with adjustable prop valve dist. block	\$299.00	\$267.00	\$210.00



MIDNITE SERIES MASTER CYLINDERS & PROPORTIONING VALVES

Ported on left side only. Available in black and chrome bails, with 1" or 1-1/8" bore.

PART #	DESCRIPTION	RETAIL	JOBBER	DEALER
MASTER CYLINDER & PROP VALVE KITS:				
MNSMCPV-K	Aluminum Cast Master Cylinder with GM-style Proportioning Valve, 1" bore, kit	\$139.00	\$119.00	\$99.00
MNS0221	Aluminum Cast Master Cylinder, black lid with black GM-style Proportioning Valve, 1" bore, kit	\$139.00	\$119.00	\$99.00
MNSBMC1	Smooth Lid Black Aluminum Master Cylinder with Adjustable Prop Valve, 1" bore, kit	\$129.00	\$109.00	\$89.00
MNSBMC2	Smooth Lid Black Aluminum Master Cylinder with Adjustable Prop Valve Distribution block, 1-1/8" bore, kit	\$139.00	\$109.00	\$99.00
PROP VALVES:				
PVKS-10	Side Mount with Black GM-style Proportioning Valve, kit	\$75.00	\$65.00	\$59.00
PVKS-00	Side Mount with Aluminum GM-style Proportioning Valve, kit	\$75.00	\$65.00	\$59.00
PVKU-10	Under Mount with Black GM-style Proportioning Valve, kit	\$89.00	\$85.00	\$75.00
PVKU-00	Under Mount with Aluminum GM-style Proportioning Valve, kit	\$89.00	\$85.00	\$75.00
PV-24BBH	Black GM-style Proportioning Valve, ea.	\$49.00	\$43.00	\$36.00
PV-24AH	Aluminum GM-style Proportioning Valve, ea.	\$49.00	\$43.00	\$36.00
APV	Adjustable Proportioning Valve, ea.	\$59.00	\$52.00	\$25.00
APV-DB	Adjustable Proportioning Valve Distribution Block	\$69.00	\$61.00	\$50.00

#MNSMCPV-K



#MNSBMC2



SIDE MOUNT KITS

GM STYLE

#PV24BBH

#PVKS-10

PART #	DESCRIPTION	RETAIL	JOBBER	DEALER
MASTER CYLINDERS:				
M-C100-APLF	1" bore Aluminum Cast Master Cylinder, ea.	\$65.00	\$59.00	\$45.00
M-C118-APLF	1-1/8" bore Aluminum Cast Master Cylinder, ea.	\$65.00	\$59.00	\$45.00
M-C100-APBLF	1" bore Aluminum Cast Master Cylinder with black lid, ea.	\$65.00	\$59.00	\$45.00
M-C118-APBLF	1-1/8" bore Aluminum Cast Master Cylinder with black lid, ea.	\$65.00	\$59.00	\$45.00
M-C100BAS	1" bore, 2 port 1/2-20, 9/16-18 thread Black Aluminum Master Cylinder with flat lid, ea.	\$79.00	\$71.00	\$63.00
M-C118BAS	1-1/8" bore, 2 port 1/2-20, 9/16-18 thread Black Aluminum Master Cylinder with flat lid, ea.	\$79.00	\$71.00	\$63.00
M-C100CAS	1" bore, 2 port 1/2-20, 9/16-18 thread Chrome Aluminum Master Cylinder with flat lid, ea.	\$89.00	\$81.00	\$71.00
M-C118CAS	1-1/8" bore, 2 port 1/2-20, 9/16-18 thread Chrome Aluminum Master Cylinder with flat lid, ea.	\$89.00	\$81.00	\$71.00

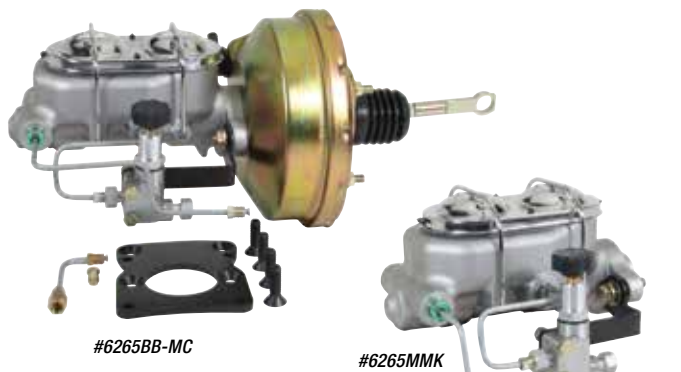

#6265BB-MC

#6265MMK

BOOSTER & MASTER CYLINDER FOR 1962-65 FAIRLANE

Our firewall booster units tuck to the firewall and include a firewall seal to prevent fumes from entering the vehicle. Kits include booster and 3/16" mounting brackets, linkage to connect to the pedal, firewall seal, and our #6265MMK master cylinder (also sold separately). Upgrade your 1962-65 Fairlane from a single to a Corvette-style dual reservoir master. Can be used with disc/drum or disc/disc applications. Includes master cylinder, adjustable valve, mounting brackets & hardware.

PART #	DESCRIPTION	RETAIL	JOBBER	DEALER
6265BB-MC	Booster/Master Cylinder, kit	\$329.00	\$289.00	\$249.00
6265MMK	Master Cylinder (disc/drum or disc/disc), kit	\$189.00	\$170.00	\$142.00

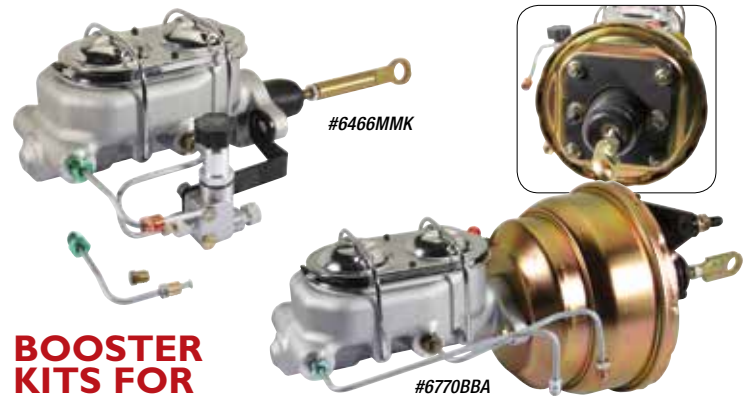

#6466MMK

#6770BBA

BOOSTER KITS FOR 1964-70 MUSTANG

Our brand new Mustang master cylinder and booster kits features a performance booster and a light weight aluminum master cylinder with a unique bracket design that accommodates both manual and power brake firewalls. Power Brake kits are available in 7 and 8 inch diameter boosters for added performance. 1964-66 booster kits includes an adjustable proportioning valve. (Will not work with Mustang Z Bars.)

PART #	DESCRIPTION	RETAIL	JOBBER	DEALER
6466MMK	1964-66 Manual Master Cylinder, kit	\$189.00	\$170.00	\$142.00
6770MMK	1967-70 Manual Master Cylinder, kit	\$189.00	\$170.00	\$142.00
6466BBA	1964-66 Power Brake Booster, kit	\$329.00	\$289.00	\$249.00
6770BBA	1967-70 Power Brake Booster, kit	\$289.00	\$249.00	\$219.00

Note: 7" and 8" dual diaphragm boosters not available for 1964-66 units.



STREET BEAST INSTALLED ON WEEK-TO-WICKED 1985 C10



PUTS OUT AN AMAZING 1800 PSI AT THE WHEELS



COMPLETE STREET BEAST™ HYDRAULIC ASSIST SYSTEMS

Our high-quality direct bolt-in hydraulic brake booster kit is designed to upgrade manual or vacuum-assisted brakes with a powerful and compact modern hydraulic assist unit. These systems include everything you need to install into your vehicle. Most installations can be accomplished in an afternoon, with average mechanical skill levels and common hand tools.

STREET BEAST SYSTEMS PACKAGE FEATURES*

- **NEW!** Hydraulic Brake Assist Unit with Black-Anodized Billet Aluminum Firewall or Frame Mount Mounting Bracket
- Aluminum Corvette-Style Master Cylinder w/Black lid & baits
- Black Adjustable Proportioning Valve Distribution Block
- **NEW!** Black Accumulator Cover
- Rubber Pressure & Return Hoses
- All Fittings & Hardware
- Fill bottle (for frame mount applications)

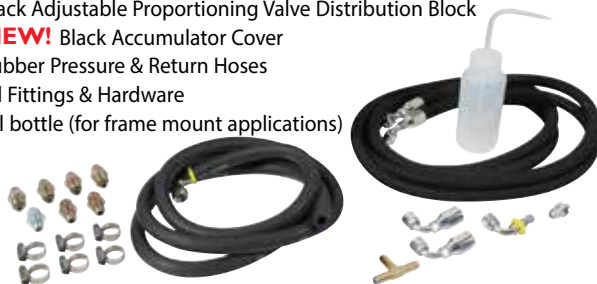

#6474HBK-SB

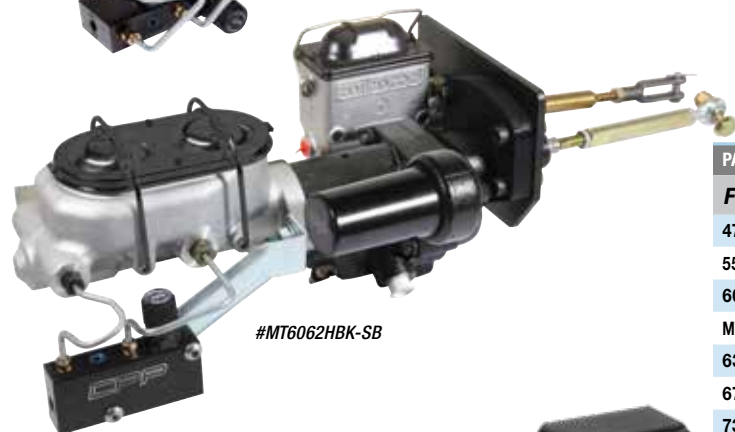

#MT6062HBK-SB



#5559HBK-SBU

PART #	DESCRIPTION	RETAIL	JOBBER	DEALER
FIREWALL MOUNT:				
4753HBK-SB	1947-53 Chevy Truck, kit	\$829.00	\$769.00	\$619.00
5559HBK-SB	1955-59 Chevy Truck, kit	\$829.00	\$769.00	\$619.00
6062HBK-SB	1960-62 Chevy Truck, kit	\$829.00	\$769.00	\$619.00
MT6062HBK-SB	1960-62 Chevy Truck, Hydraulic Clutch, kit	\$829.00	\$769.00	\$619.00
6366HBK-SB	1963-66 Chevy Truck, kit	\$829.00	\$769.00	\$619.00
6772HBK-SB	1967-72 Chevy Truck, kit	\$829.00	\$769.00	\$619.00
7387HBK-SB	1973-87 Chevy Truck, kit	\$829.00	\$769.00	\$599.00
4852HBK-SB	1948-52 Ford Truck, kit	\$829.00	\$769.00	\$619.00
5356HBK-SB	1953-56 Ford Truck, kit	\$829.00	\$769.00	\$619.00
5564HBK-SB	1955-64 Chevy Fullsize (small block applications), kit *	\$829.00	\$769.00	\$619.00
5564HBK-SB90	1955-64 Chevy Fullsize (big block applications)	\$879.00	\$809.00	\$609.00
6570HBK-SB	1965-70 Chevy Fullsize, kit	\$829.00	\$769.00	\$619.00
6267HBK-SB	1962-67 Nova, (for Mustang II/ Aftermarket IFS only), kit *	\$829.00	\$769.00	\$619.00
6474HBK-SB	1967-69 Camaro, 1968-74 Nova, 1964-72 Chevelle, kit	\$829.00	\$769.00	\$619.00
7081HBK-SB	1970-81 Camaro, kit	\$829.00	\$769.00	\$619.00
7887HBK-SB	1978-87 G-Body, (no prop valve), kit	\$809.00	\$749.00	\$599.00
FRAME MOUNT:				
4754HBK-SB	1947-53 Chevy Truck, kit	\$829.00	\$769.00	\$619.00
5559HBK-SBU	1955-59 Chevy Truck, kit	\$829.00	\$769.00	\$619.00

* Kit contains may vary per application. Images may be representative only. 1962-67 Nova kits are for use with an aftermarket, Mustang II-type subframe only.

SCAN QR CODE:
to view installation of Street Beast System and more!



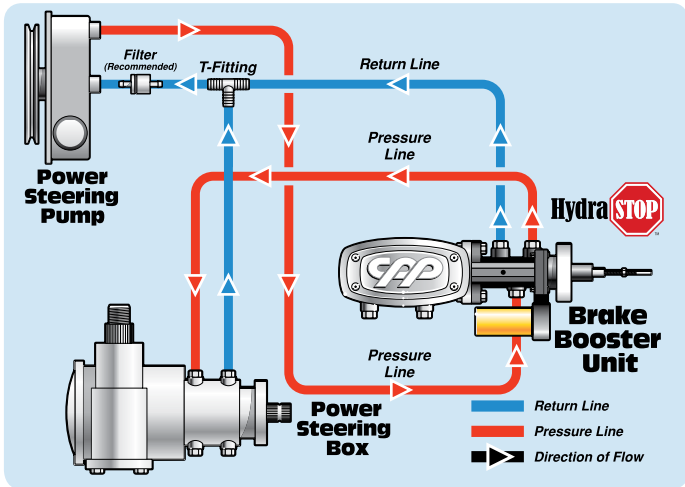

SHOW STOPPER

ALL NEW PARTS!

SHOW QUALITY
BILLET ALUMINUM, CHROME &
STAINLESS FEATURES

RE-DESIGNED!



SHOW STOPPER™ SYSTEMS PACKAGE FEATURES*

- **NEW!** Hydraulic Brake Assist Unit with Billet Aluminum Firewall or Frame Mount Mounting Bracket
- Chrome Corvette-Style Master Cylinder
- Chrome Adjustable Proportioning Valve Distribution Block
- Chrome Accumulator Cover
- Stainless Pressure Hoses & Rubber Return Hoses
- All Fittings & Hardware



PART #	DESCRIPTION	RETAIL	JOBBER	DEALER
FRAME MOUNT:				
4754HBK-SS	1947-54 Chevy Truck, kit	\$979.00	\$909.00	\$735.00
FIREWALL MOUNT:				
7387HBK-SS	1973-87 Chevy Truck, kit	\$959.00	\$889.00	\$705.00
4852HBK-SS	1948-52 Ford Truck, kit	\$979.00	\$909.00	\$735.00
5356HBK-SS	1953-56 Ford Truck, kit	\$979.00	\$909.00	\$735.00
6570HBK-SS	1965-70 Chevy Fullsize, kit	\$979.00	\$909.00	\$735.00
6267HBK-SS	1962-67 Nova, (for Mustang II/ Aftermarket IFS only), kit *	\$979.00	\$909.00	\$735.00
7081HBK-SS	1970-81 Camaro, kit	\$979.00	\$909.00	\$735.00
7887HBK-SS	1978-87 G-Body, (no prop valve), kit	\$959.00	\$889.00	\$705.00

* 1962-67 Nova kits are for use with an aftermarket, Mustang II-type subframe only.



HYDRAULIC ASSIST BARE UNITS

Our Hydrastop™ units are also available as a stand-alone unit. This makes switching to hydraulically assisted brakes easier than ever. If you currently are running a larger vacuum assisted booster setup on your car but are lacking vacuum these will allow you to use your current Power Brake 1-1/8" bore Chevy master cylinder (3-3/8" mounting flange).



#6474HBK-BSB

NEW!

STREET BEAST BARE UNITS FEATURE:

- Hydraulic Brake Assist Unit
- Billet Aluminum Mounting Bracket with Black Anodized Finish (for Street Beast™)
- Mounting Hardware

PART #	DESCRIPTION	RETAIL	JOBBER	DEALER
FRAME MOUNT:				
4754HBK-BSB	1947-54 Chevy Truck, ea.	\$469.00	\$439.00	\$349.00
5559HBK-BSBU	1955-59 Chevy Truck, Undermount, ea.	\$469.00	\$439.00	\$349.00
FIREWALL MOUNT:				
4753HBK-BSB	1947-53 Chevy Truck, ea.	\$469.00	\$439.00	\$349.00
6062HBK-BSB	1960-62 Chevy Truck, ea.	\$469.00	\$439.00	\$349.00
MT6062HBK-BSB	1960-62 Chevy Truck, Hydraulic Clutch, ea.	\$469.00	\$439.00	\$349.00
6366HBK-BSB	1963-66 Chevy Truck, ea.	\$469.00	\$439.00	\$349.00
6772HBK-BSB	1967-72 Chevy Truck, ea.	\$469.00	\$439.00	\$349.00
7387HBK-BSB	1973-87 Chevy Truck, ea.	\$469.00	\$439.00	\$349.00
5564HBK-BSB	1955-64 Chevy Fullsize, (small block applications) ea.	\$469.00	\$439.00	\$349.00
5564HBK-BSB90	1955-64 Chevy Fullsize (big block applications), ea.	\$519.00	\$489.00	\$409.00
6570HBK-BSB	1965-70 Chevy Fullsize, ea.	\$469.00	\$439.00	\$349.00
6267HBK-BSB	1962-67 Nova, (for Mustang II/ Aftermarket IFS only), ea. *	\$469.00	\$439.00	\$349.00
6474HBK-BSB	1968-74 Nova, 1967-69 Camaro, 1964-72 Chevelle, ea.	\$469.00	\$439.00	\$349.00
7081HBK-BSB	1970-81 Camaro, ea.	\$469.00	\$439.00	\$349.00
7887HBK-BSB	1978-87 G-Body, ea.	\$469.00	\$439.00	\$349.00

* 1962-67 Nova kits are for use with an aftermarket, Mustang II-type subframe only. NOTE: See Part # HAHK-R and HAHK-S for Hydrastop hose kits available separately.



NEW!

SHOW STOPPER BARE UNITS FEATURE:

- Hydraulic Brake Assist Unit
- Billet Aluminum Mounting Bracket with Clear Anodized Finish (for Show Stopper™)
- Mounting Hardware

#7387HBK-BSS

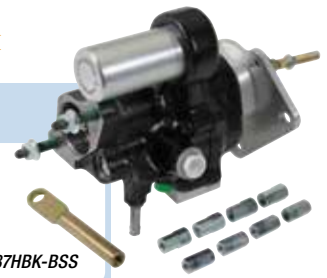

PART #	DESCRIPTION	RETAIL	JOBBER	DEALER
FRAME MOUNT:				
4754HBK-BSS	1947-54 Chevy Truck, ea.	\$549.00	\$509.00	\$409.00
FIREWALL MOUNT:				
7387HBK-BSS	1973-87 Chevy Truck, ea.	\$549.00	\$509.00	\$409.00
6570HBK-BSS	1965-70 Chevy Fullsize, ea.	\$549.00	\$509.00	\$409.00
6267HBK-BSS	1962-67 Nova, (for Mustang II/ Aftermarket IFS only), ea. *	\$549.00	\$509.00	\$409.00
7081HBK-BSS	1970-81 Camaro, ea.	\$549.00	\$509.00	\$409.00
7887HBK-BSS	1978-87 G-Body, ea.	\$549.00	\$509.00	\$409.00

* 1962-67 Nova kits are for use with an aftermarket, Mustang II-type subframe only. NOTE: See Part # HAHK-R and HAHK-S for Hydrastop hose kits available separately.

Classic Performance Products, Inc.

BRAKES / HYDRAULIC ASSIST ACCESSORIES



#HAHK-R



#HAHK-S



HYDRAULIC BRAKE ASSIST HOSE KITS

We offer complete hose kits for completing your Hydraulic assist system installs. Our kits include all the fittings and hoses needed to plumb your complete power steering and booster kit. Fittings include both SAE inverted flare and metric O-ring for your power steering pump and -AN fitting for your hose ends. Hoses are available in 4' (most firewall applications) and 6' (perfect for custom routing and under floor mount assemblies) lengths. Available in stainless and traditional rubber hose.

PART #	DESCRIPTION	RETAIL	JOBBER	DEALER
HAHK-R	4' Rubber Return & Pressure Hose, kit	\$115.00	\$104.00	\$85.00
HAHK-S	4' Rubber Return & Stainless Pressure Hose, kit	\$199.00	\$180.00	\$149.00
HAHK-R6	6' Rubber Return & Pressure Hose, kit	\$140.00	\$127.00	\$110.00
HAHK-S6	6' Rubber Return & Stainless Pressure Hose, kit	\$225.00	\$205.00	\$169.00
CP-HFK	Hydrastop™ Fitting Kit, kit	\$30.00	\$26.00	\$21.00



FITTING KIT #CP-HFK



#HBA-IK

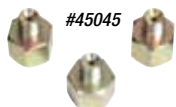

#45045



#CP5100

#BP5100

#RP5100



HYDRAULIC BRAKE ASSIST ACCESSORIES

Our new Install Kit features an in-line filter, fitting kit and brake bleeding syringe. Our in-line filtration extends steering system life and ensures proper performance over the long haul. The fitting kit consists of three brake line adapters with 3/8-24 inverted flare male and three different inverted flare female ends. The included curved tip syringe makes bleeding a snap as well as being brake fluid and solvent resistant. And don't forget to finish off your Hydrastop™ unit with one of our various accumulator covers for that show quality finish.

PART #	DESCRIPTION	RETAIL	JOBBER	DEALER
HBA-IK	Hydraulic Brake Assist Install Kit, kit	\$29.00	\$26.00	\$20.00
PSFF-K	In-Line Fuel Filter & Fitting Kit, 3/8" lines, kit	\$16.00	\$14.00	\$12.00
PSF-AN	In-Line Filter Only, 3/8" lines, ea.	\$11.00	\$10.00	\$9.00
CP0105	Brake Bleeding Syringe, curved tip, ea.	\$5.00	\$4.00	\$3.00
45045	Prop Valve/Master Cylinder Adapter Fitting Kit, kit	\$15.00	\$13.00	\$10.00
CP5100	Chrome Accumulator Cover, ea.	\$69.00	\$62.00	\$48.00
RP5100	Aluminum Accumulator Cover, ea.	\$30.00	\$25.00	\$20.00
BP5100	Black Accumulator Cover, ea.	\$39.00	\$35.00	\$30.00



#49032

#49033

#49034

BANJO FITTINGS

Solve your tight install issues by using our 90 degree banjo to -6AN adapters. Straight adapters are often difficult and require more room to work with so these 90 degree adapters will allow for a tight-fit, professional looking hose setup.

PART #	DESCRIPTION	RETAIL	JOBBER	DEALER
HBAN90	90 Straight Banjo AN Fitting, kit	\$30.00	\$26.00	\$22.00
49032	AN-6 to 5/16-24 Banjo Fitting, ea.	\$10.00	\$9.00	\$8.00
49033	AN-6 to M16-1.5 Banjo Fitting, ea.	\$10.00	\$9.00	\$8.00
49034	AN-6 to M18-1.5 Banjo Fitting, ea.	\$10.00	\$9.00	\$8.00



#45117

#45115

POWER STEERING PUMP FITTINGS

Our power steering flow valves are designed to be used with late model Type II pumps. Some applications require lower flow for smoother operation or to convert to a high flow for applications like our 500 Series™ steering gearbox and Hydrastop™ applications.

PART #	DESCRIPTION	RETAIL	JOBBER	DEALER
45117	Type II High Flow, ea.	\$20.00	\$17.00	\$14.00
45115	Type II Low Flow, ea.	\$20.00	\$17.00	\$14.00



MORE FITTING AVAILABLE SEE PAGES 31-32

13" BIG BRAKES!

1965-72 FORD TRUCK

1965-72 FORD TRUCK MODULAR™ STOCK SPINDLE BIG BRAKE KITS

Our NEW Modular Ford Truck Spindle BIG Brake kits are finally here! This kit was designed and manufactured just for trucks with 17" or larger wheels! For the first time ever we can offer you a brake system making converting to BIG modern disc brakes, bolt-on easy! These kits feature Modular spindles that have an anti-rust, black finish coating, 13" rotors, BIG Twin Piston loaded floating calipers, new king pins and all the hoses, bearings and seals needed to complete the installation. These kits are the perfect way to rebuild your Ford Truck front axle and add a BIG Brake kit for your 17" or larger wheels! (13" rotors come standard with the original 5 on 5-1/2 five bolt pattern).

PART #	DESCRIPTION	INTRO PRICE WON'T LAST LONG!	RETAIL	JOBBER	DEALER
6572SWBK-MT	1965-72 Ford Truck, 13" Big Brake Kit		\$949.00	\$969.00	\$825.00
K512D	King Pin Kit, kit		\$75.00	\$68.00	\$61.00



SPECIAL ORDER AVAILABLE FOR OTHER BOLT PATTERNS

13" BIG BRAKE KIT FEATURES*

- 13" Cross-Drilled & Gas-Slotted Rotors, 5x5.5 Bolt Pattern
- * Also available in other bolt patterns, please inquire.
- Modular™ Stock Spindles
- Aluminum Hubs with Screw-in Studs
- PBR C15 calipers with Dual 52mm pistons
- Caliper Brackets
- Brand New King Pin Rebuild Kit
- Bearings, Seals, Rubber Hoses, Clips & Hardware

Note: These kits require 17" or larger wheels. Kit is also available in other bolt patterns (must be special order).



1965-72 FORD TRUCK

DISC BRAKE KIT FEATURES*

- Modular™ Stock Spindles
- Loaded Calipers
- 12" Standard Rotors
- Bearings, Seals, Rubber Hoses & Clips
- Brand New King Pin Rebuild Kit
- All Mounting Hardware

1965-72 FORD TRUCK MODULAR™ STOCK SPINDLE 12" DISC BRAKE KITS

The waiting is over, our NEW Modular Ford Truck Spindle Brake kits are finally here, making converting to a newer, more modern disc brakes, bolt-on easy! These kits feature Modular Spindles, 12" rotors, big single piston loaded full floating calipers, new king pins and all the hoses, bearings and seals needed to complete the installation. These kits are the perfect way to rebuild your Ford Truck front axle and add modern disc brakes in bolt on fashion. (12" rotors are only available in the original 5 on 5-1/2 five bolt pattern).

PART #	DESCRIPTION	RETAIL	JOBBER	DEALER
6572SWBK-12	1965-72 Ford Truck, kit	\$599.00	\$527.00	\$449.00



SHOWN WITH OPTIONAL UPGRADED ROTORS.

1965-72 FORD TRUCK

DISC BRAKE KIT FEATURES*

- OE-Style Stock Spindles
- Loaded Ford Calipers
- 12" Standard Rotors
- Bearings, Seals, Rubber Hoses & Clips
- Brand New King Pin Rebuild Kit
- All Mounting Hardware

1965-72 FORD TRUCK OE STOCK SPINDLE WHEEL BRAKE KIT

No more waiting for reconditioned spindles! CPP now offers a brand new OE stock style spindle for the 1965-72 Ford trucks to make upgrading to disc conversation much easier. Our direct bolt-on kits include stock height spindles, King pin kit, 5 x 5.5 Bolt pattern rotors, calipers and mounting brackets, bearings, seals and hoses. Spindles and new king pin kit also available separately to work with later F100 brake components.

PART #	DESCRIPTION	RETAIL	JOBBER	DEALER
6572SWBK-FT	1965-72 Ford Truck, kit	\$599.00	\$527.00	\$449.00
6572FSN	1965-72 Stock-Style Spindles, pair	\$249.00	\$219.00	\$186.00

NEW OE-STYLE FORD SPINDLES



NOW AVAILABLE!!

BRAKES / CORVETTE-STYLE SPINDLE BRAKE KITS

QUICK FACTS...

STOCK/DROP	stock
ROTOR	13"
CALIPER	(2)40.5mm
OFFSET	0
MIN. WHEEL SIZE	17"
BACKSPACING	factory

#7081SWBK-SC7R



CPP's **Comeback Camaro**

1967 CAMARO

CORVETTE-STYLE SPINDLE WHEEL BRAKE KITS WITH PERFORMANCE HUB UPGRADE

CPP introduces its newest addition to the Corvette style spindle product line. Our high performance Corvette style wheel brake kit utilizes a C7 Corvette style hub assembly, which includes heavy duty 1/2-20"x 2" screw-in wheel studs and a stronger sealed bearing pack. With a sealed bearing pack, flex on the factory spindle pin, which causes caliper piston push back is resolved. This condition is especially a problem on aftermarket multi-piston radial mount style calipers. This kit also includes our Corvette style spindles, which are a direct bolt-on for a Nova, Chevelle and Camaro (early Camaro kit uses original or CPP replacement steering arms). The early AFX body tall spindle helps with improved geometry by giving a better camber change during suspension movement and also maintains the drum brake offset. Specify black or red calipers.

HIGH PERFORMANCE C7 CORVETTE-STYLE HUB ASSEMBLY WITH 1/2-20 SCREW-IN STUDS

WHEEL BRAKE KIT FEATURES*

- Corvette-Style Spindles
- 13" Front Drilled/Slotted Rotors
- Large, Dual-Piston, Loaded Black or Red Calipers
- C7 High Performance Corvette-Style Hubs with 1/2-20 Screw-in Studs & Sealed Bearings
- Braided Stainless Steel Hose Kit
- Works with Stock or CPP Totally Tubular™ Control Arms

CORVETTE-STYLE WHEEL BRAKE KITS

PART #	DESCRIPTION	RETAIL	JOBBER	DEALER
6474SWBK-STC7B	1967-69 Camaro, (tall spindle) black calipers, kit	\$849.00	\$789.00	\$680.00
6474SWBK-STC7R	1967-69 Camaro, (tall spindle) red calipers, kit	\$849.00	\$789.00	\$680.00
7081SWBK-SC7B	1975-79 Nova, 1970-81 Camaro, 1973-77 Chevelle, black calipers, kit	\$849.00	\$789.00	\$680.00
7081SWBK-SC7R	1975-79 Nova, 1970-81 Camaro, 1973-77 Chevelle, red calipers, kit	\$849.00	\$789.00	\$680.00

NOTE: These kits utilize a 13" rotor and require a minimum 17" wheel. It is recommended that you use CPP's front brake hose tabs for 1967-69 Camaro (#6769FDBL-TK). Also, these kits will not work with CPP budget tubular control arms #6774ETA-K.

CORVETTE-STYLE SPINDLES

PART #	DESCRIPTION	RETAIL	JOBBER	DEALER
CP30019	1955-57 Fullsize Drop, pr.	\$269.00	\$249.00	\$195.00
CP30013	1967-69 Camaro, 1968-74 Nova, 1964-72 Chevelle, Stock, pr.	\$269.00	\$249.00	\$195.00
CP30014	1970-81 Camaro & 1975-79 Nova Stock, pr.	\$269.00	\$249.00	\$195.00
CP30017	1967-69 Camaro, 1968-74 Nova, 1964-72 Chevelle, Drop, pr.	\$269.00	\$249.00	\$195.00
CP30016	1978-87 G-Body Stock, pr.	\$269.00	\$249.00	\$195.00



CORVETTE-STYLE HUB UPGRADES

Whether you're working on your daily driver or high performance Pro-Touring vehicle, CPP offers different options for Corvette-style hub assemblies.

PART #	DESCRIPTION	RETAIL	JOBBER	DEALER
513139	Entry level C5 hub assembly, M12-1.5 metric press-in studs, ea. (*)	\$79.00	\$71.00	\$59.00
CP35036	High Performance C7 hub assembly, 1/2-20" screw-in wheel studs, ea. (**)	\$199.00	\$175.00	\$149.00
20981829	SKF - C7 hub assembly, M12-1.5 metric press-in studs, ea. (***)	\$149.00	\$141.00	\$134.00
BR930544	SKF - X-Tracker Hub Assembly, M12-1.5 metric press-in studs, ea.	\$429.00	\$404.00	\$379.00

Note: *513139 is included in our Entry Level Corvette-Style Wheel Brake Kit. **CP35036 is included with our High Performance Corvette-Style Wheel Brake Kit. ***20981829 does not include wire connector for wheel sensor.



6-PISTON PRO-SERIES BIG BRAKES

MORE BRAKE PISTON = MORE BRAKE FORCE!

PRO Series

NOW AVAILABLE!



6-PISTON 14" BIG BRAKE PACKAGE FEATURES*

- 2-Piece Pre-Assembled Drilled/Slotted & Zinc Coated Rotors
- 6-Piston Billet Aluminum Stationary Calipers
- NAS Premium Stainless Hardware
- Braided Set Stainless Brake Hose Kit

6-PISTON FRONT BIG BRAKE KIT

The 6 piston calipers are a 2-piece forged caliper design with six cross bolts for added strength. The piston sizes are staggered to minimize tapered pad wear and it uses the same pad as the C5 (1997-2004) and C6 (2005-2012) Corvette for an easy-to-find, cost effective pad replacement. Includes stainless steel pistons, abutments, noise suppression springs and dual seals (dust/weather pressure) to meet DOT specifications. Kits come with proper banjo fittings, not pipe thread fittings. Available for stock, Modular, X-10 Xtreme and CS Corvette-style spindles. Available with black or red calipers.

PART #	DESCRIPTION	RETAIL	JOBBER	DEALER
14" FRONT				
6087B6WK-5D14	1960-87 Chevy Truck, 5x5 lug (for Modular drop spindles), kit	\$2,295.00	\$2,180.00	\$2,019.00
6087B6WK-6D14	1960-87 Chevy Truck, 6x5 lug (for Modular drop spindles), kit	\$2,295.00	\$2,180.00	\$2,019.00
5568B6WK-S14	1955-68 Chevy Fullsize (for stock spindles), kit	\$2,295.00	\$2,180.00	\$2,019.00
5870B6WK-D14	1958-70 Chevy Fullsize (for Modular drop spindles), kit	\$2,295.00	\$2,180.00	\$2,019.00
6481B6WK-CS14	1968-74 Nova, 1967-69 Camaro, 1964-72 Mid-Size (for Corvette-style spindles), kit	\$1,895.00	\$1,800.00	\$1,667.00
6472B6WK-S14	1964-72 Mid-Size (for stock spindles), kit	\$2,295.00	\$2,180.00	\$2,019.00
7888B6WK-CS14	1978-88 G Body (for Corvette-style spindles), kit	\$1,895.00	\$1,800.00	\$1,667.00

PART #	DESCRIPTION	RETAIL	JOBBER	DEALER
13" FRONT				
5568B6WK-S13	1955-68 Chevy Fullsize (for stock spindles), kit	\$2,295.00	\$2,180.00	\$2,019.00
5870B6WK-D13	1958-70 Chevy Fullsize (for Modular drop spindles), kit	\$2,295.00	\$2,180.00	\$2,019.00
6481B6WK-CS13	1968-74 Nova, 1967-69 Camaro, 1964-72 Mid-Size (for stock spindles), kit	\$2,295.00	\$2,180.00	\$2,019.00

Note: 14" kits utilize a 14" rotor and require a minimum 18" wheel. 13" kits utilize a 13" rotor and require a minimum 17" wheel.



6-PISTON REAR BIG BRAKE KIT

Rear kits also available with 6 piston calipers. Rear calipers have the exact same look as the front. Rear calipers are machined specifically for rear applications and have smaller, yet staggered pistons to minimize pad taper. Rear kits incorporate a drum in hat park brake. Kits come with proper banjo fittings, not pipe thread fittings. Available with black or red calipers.

6-PISTON 14" BIG BRAKE PACKAGE FEATURES*

- 2-Piece Pre-Assembled Drilled/Slotted & Zinc Coated Rotors
- Calipers & brackets
- Emergency Brake Hose Hardware
- Hard Lines & Hoses
- All Mounting Hardware

PART #	DESCRIPTION	RETAIL	JOBBER	DEALER
14" REAR				
6087B6RWBK-514	1960-87 Chevy Truck, 5-Lug pattern, kit	\$2,295.00	\$2,180.00	\$2,019.00
6087B6RWBK-614	1960-87 Chevy Truck, 6-Lug pattern, kit	\$2,295.00	\$2,180.00	\$2,019.00
5557B6RWBK-S14	1955-57 Fullsize, stock rear end, kit	\$2,295.00	\$2,180.00	\$2,019.00
5864B6RWBK-S14	1958-64 Fullsize, stock rear end, kit	\$2,295.00	\$2,180.00	\$2,019.00
6570B6RWBK-S14	1965-70 Fullsize, stock rear end, kit	\$2,295.00	\$2,180.00	\$2,019.00
6769B6RWBK-B14	1967-69 Camaro, stock bearing on axle BOP rear end, kit	\$2,295.00	\$2,180.00	\$2,019.00
6774B6RWBK-S14	1967-69 Camaro, 1968-74 Nova, stock 10 or 12 bolt C-Clip rear end, kit	\$2,295.00	\$2,180.00	\$2,019.00

PART #	DESCRIPTION	RETAIL	JOBBER	DEALER
7074B6RWBK-C14	1970-74 Camaro, stock C-clip rear end, kit	\$2,295.00	\$2,180.00	\$2,019.00
7581B6RWBK-C14	1975-81 Camaro, stock C-clip rear end, kit	\$2,295.00	\$2,180.00	\$2,019.00
6477B6RWBK-S14	1964-77 Mid-size, stock 10 or 12 bolt C-clip rear end, kit	\$2,295.00	\$2,180.00	\$2,019.00
6472B6RWBK-B14	1964-72 Mid-Size, stock bearing on axle BOP rear end, kit	\$2,295.00	\$2,180.00	\$2,019.00
7888B6RWBK-S14	1978-88 G Body, stock 10 bolt rear end, kit	\$2,295.00	\$2,180.00	\$2,019.00
9B6RWBK-114	Ford 9" rear end, 5x4.5 and 5x4.75 lug pattern (does not include parking brake cable), kit	\$2,245.00	\$1,980.00	\$1,819.00
9B6RWBK-214	Ford 9" rear end, 5x5 lug pattern (does not include parking brake cable), kit	\$2,245.00	\$1,980.00	\$1,819.00

Note: 14" kits utilize a 14" rotor and require a minimum 18" wheel.

Classic Performance Products, Inc.

BRAKES / 4 PISTON SS SERIES BIG BRAKES

4 PISTON SS Series

4-PISTON 13" REAR BIG BRAKE KIT

4-PISTON 13" BIG BRAKE PACKAGE FEATURES*

- 13" 2-Piece Drilled/Slotted & Zinc Coated Rotors
- 4-Piston Billet Aluminum Calipers with Unique Billet Backing
- Parking Brake Cables (Except 9" Ford)
- Stainless Steel Brake Hoses
- All Necessary Hardware

Our new 13" 4 Piston rear brake kits feature powdercoated 2-piece billet aluminum calipers with hard anodized aluminum pistons, full 2-piece rotor 13" vaned, drilled and slotted rotors, fully machined billet mounting brackets that install the calipers as well as incorporate an internal drum in hat parking brake design. DOT-approved dual seal piston seals making these kits fully street able and perfect for track use as well! These kits are complete and available for 10-bolt, 12-bolt and 9" Ford rear ends. Available with black or red calipers.



#6087B4RWK

PART #	DESCRIPTION	RETAIL	JOBBER	DEALER
6087B4RWBK-513	1960-87 Chevy Truck, 5-Lug pattern, kit	\$1,295.00	\$1,230.00	\$1,139.00
6087B4RWBK-613	1960-87 Chevy Truck, 6-Lug pattern, kit	\$1,295.00	\$1,230.00	\$1,139.00
5557B4RWBK-S13	1955-57 Fullsize, stock rear end, kit	\$1,395.00	\$1,325.00	\$1,227.00
5864B4RWBK-S13	1958-64 Fullsize, stock rear end, kit	\$1,395.00	\$1,325.00	\$1,227.00
6570B4RWBK-S13	1965-70 Fullsize, stock rear end, kit	\$1,395.00	\$1,325.00	\$1,227.00
6769B4RWBK-B13	1967-69 Camaro, stock bearing on axle BOP rear end, kit	\$1,395.00	\$1,325.00	\$1,227.00
6774B4RWBK-S13	1967-69 Camaro, 1968-74 Nova, stock 10 or 12 bolt C-Clip rear end, kit	\$1,395.00	\$1,325.00	\$1,227.00
7074B4RWBK-C13	1970-74 Camaro, stock C-clip rear end, kit	\$1,395.00	\$1,325.00	\$1,227.00

PART #	DESCRIPTION	RETAIL	JOBBER	DEALER
7581B4RWBK-C13	1975-81 Camaro, stock C-clip rear end, kit	\$1,395.00	\$1,325.00	\$1,227.00
6477B4RWBK-S13	1964-77 Mid-size, stock 10 or 12 bolt C-clip rear end, kit	\$1,395.00	\$1,325.00	\$1,227.00
6472B4RWBK-B13	1964-72 Mid-Size, stock bearing on axle BOP rear end, kit	\$1,395.00	\$1,325.00	\$1,227.00
7888B4RWBK-S13	1978-88 G Body, stock 10 bolt rear end, kit	\$1,395.00	\$1,325.00	\$1,227.00
9B4RWBK-113	Ford 9" rear end, 5x4.5 and 5x4.75 lug pattern (does not include parking brake cable), kit	\$1,345.00	\$1,277.00	\$1,183.00
9B4RWBK-213	Ford 9" rear end, 5x5 lug pattern (does not include parking brake cable), kit	\$1,345.00	\$1,277.00	\$1,183.00

Note: These kits utilize a 13" rotor and require a minimum 17" wheel.

1949-54 CHEVY CAR COMPLETE DISC BRAKE UPGRADE KIT

Our complete disc upgrade is available for early 1949-54 Chevrolet Fullsize cars with manual transmissions. Kits include caliper mounting brackets, vented rotors, brand new calipers and pads, bearings, seals, hoses and all mounting hardware to assemble onto your stock drum spindles. Kits also include a master cylinder and adjustable proportioning valve along with a full bend-to-fit brake line kit. Bolt pattern is 5 x 4.75. Kits require a 15" or larger disc brake wheel.



#4954CBK-S

FULL "BEND TO FIT" BRAKE LINE KIT

PART #	DESCRIPTION	RETAIL	JOBBER	DEALER
4954CBK-S	Complete kit with Master Cylinder and Intall Kit, kit	\$599.00	\$527.00	\$449.00
4954MCAPV	Master Cylinder with Adjustable Prop Valve Kit, ea.	\$269.00	\$242.00	\$199.00

1964-66 FORD MUSTANG PARKING BRAKE CABLES

CPP's parking brake cable for the 1964-66 Mustang uses the OE clamps and routing under the car. 1964-65 Mustangs will need to update to a 1966 parking brake equalizer to adapt the parking brake cable.

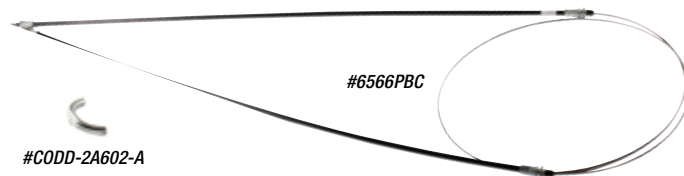

#C0DD-2A602-A

PART #	DESCRIPTION	RETAIL	JOBBER	DEALER
6566PBC	1964-66 Mustang	\$89.00	\$78.00	\$65.00
C0DD-2A602-A	Parking Brake Equalizer	\$15.00	\$14.00	\$12.00

E-STOPP KIT

E-Stop® is a push-button electric emergency brake that not only frees up room on the chassis and in the cab; it also doubles as an anti-theft device when the button is hidden. It works with any kind of brake system that can accept an e-brake cable and can mount anywhere on the chassis where you have room. Kit contains actuator, controller and push-button. CPP has made it easier to install your E-Stop actuator and button by offering a wide range of mounting options, no matter what application you have. Our universal mounting bracket kit (#ESMB) is ideal when a frame rail isn't available and you must install to the body floor. This kit works best for unibody applications. Our single and dual cable mounting brackets allows for a super clean option to mount the E-stop cable and the parking brake cable. Our button mounting bracket (#ESBB) comes with everything needed to secure the activation button to your under dash.



PART #	DESCRIPTION	RETAIL	JOBBER	DEALER
ESK001	E-Stop kit	\$479.00	\$455.05	\$431.10
ESB001	Machined Bracket, ea.	\$38.00	\$36.00	\$34.00
ESMB	Universal Mounting Bracket, kit	\$79.00	\$69.00	\$59.00

PART #	DESCRIPTION	RETAIL	JOBBER	DEALER
ESSB	Single Cable Frame Bracket, ea.	\$18.00	\$16.00	\$13.00
ESDB	Double Cable Frame Bracket, ea.	\$18.00	\$16.00	\$13.00
ESBB	Button Bracket, ea.	\$12.00	\$11.00	\$9.00

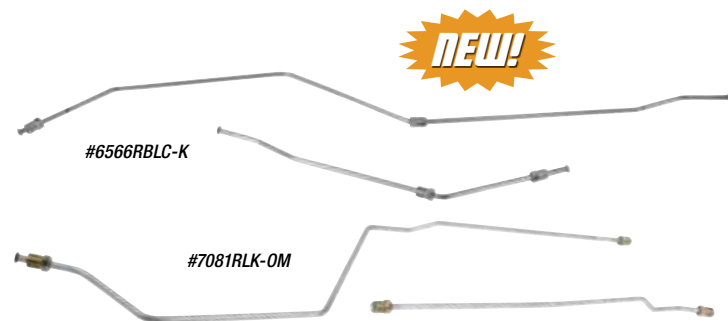

NEW!

BRAKE LINE CONVERSION KITS

Complete front disc brake line kits are now available for both firewall mounted booster kits and underfloor mounted assemblies. Take the trial and error equation out of forming your own lines with these pre-bent lines. Direct fit for applications listed. Also available for rear disc conversions.

PART #	DESCRIPTION	RETAIL	JOBBER	DEALER
FRONT KITS:				
5559FPBL-K	1955-59 Chevy Truck Firewall Power Brake	\$79.00	\$70.00	\$65.00
5559FMBL-K	1955-59 Chevy Truck Firewall Manual Brake	\$79.00	\$70.00	\$65.00
5559UPBL-K	1955-59 Chevy Truck Undermount Power Brake	\$79.00	\$70.00	\$65.00
5559UMBL-K	1955-59 Chevy Truck Undermount Manual Brake	\$79.00	\$70.00	\$65.00
6568FBLC-K	1965-68 Mustang	\$75.00	\$70.00	\$65.00
6265FBLC-K	1962-65 Fairlane	\$75.00	\$70.00	\$65.00

REAR AXLE KITS:

5559RBLC-K	1955-59 Chevy Truck, kit	\$35.00	\$32.00	\$29.00
6566RBLC-K	1965-66 Mustang, kit	\$35.00	\$32.00	\$29.00
7081RLK-OM	1970-81 Camaro, kit	\$35.00	\$32.00	\$29.00
7887RBLC-K	1978-87 G-Body, kit	\$35.00	\$32.00	\$29.00



#UBCM



#CP-UBCK

UNIVERSAL BRAKE CABLE MOUNT

Our universal emergency brake cables are great for any custom car or truck where a factory cable just won't work. These are designed to be used with rear disc conversions as well as drum brakes. Outer housings are simply cut-to-length then installed, after that simply run the inner cables and cut-to-length and junction to the unique clevis end with double set screws. Available in traditional black. Kits include all mounting hardware and ends. CPP also offers a universal parking brake cable mounting kit that includes two single cable brackets so you can mount at any angle necessary.

PART #	DESCRIPTION	RETAIL	JOBBER	DEALER
CP-UBCK	black cable, kit	\$89.00	\$79.00	\$69.00
UBMC	cable mounts, kit	\$18.00	\$16.00	\$13.00

Classic Performance Products, Inc.

FRAME / COMPLETE FRAME PACKAGES

PRO-TOURING PACKAGES

CPP's new Pro-Touring Kits are the most complete packages on the market and offer the ultimate in performance upgrades to your car or truck for an affordable price. Our kits come in 4 different stages, from suspension only (Stage I & II) to full kits (Stage III & IV) including front and rear brake packages. Our kits are made in the USA with the quality you have come to expect from Classic Performance Products, Inc. All our PTK kits include front and rear Totally Tubular™ upper and lower control arms, front and rear Pro-Touring sway bars with an optional billet aluminum mount upgrade, lowered front and rear coil springs with nitrogen gas shocks in the PTK1 or the dual-adjustable coil over package with rear dual-adjustable shocks (PTK2, PTK3, PTK4), lowered rear leaf springs (for leaf spring applications). Add CPP's chrome master cylinder/adjustable stop-block combo along with our front and rear 11" or 13" Big Brake disc brake kits, and you have a "tried and true" Pro-Touring package in the PTK3 (Stage III) and PTK4 (Stage IV) kits.



1955-57 CHEVY FULLSIZE

PTK-1 KIT INCLUDES:

- Upper Totally Tubular™ Control Arms
- Lower Totally Tubular™ Control Arms
- Front Sway Bar Kit
- Rear Pro-Touring Sway Bar Kit
- Front Lowered Coil Springs
- Front & Rear Classic Fit™ Nitrogen Gas Shocks
- Rear Lowered Leaf Springs

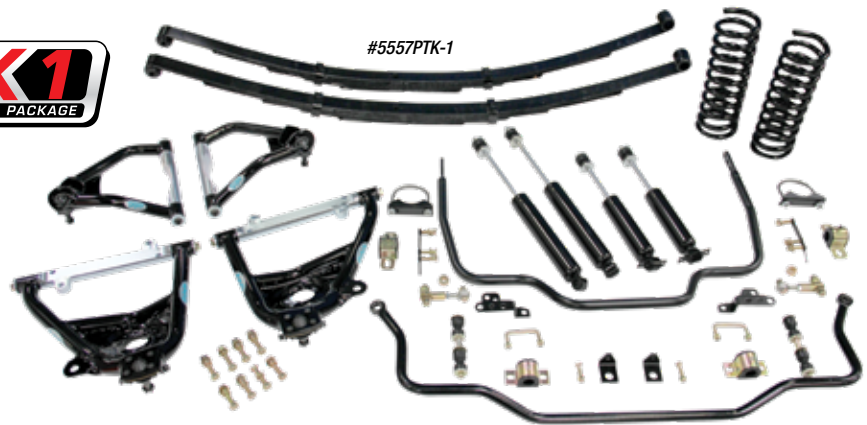

#5557PTK-1

#5557PTK-2



1955-57 CHEVY FULLSIZE

PTK-2 KIT INCLUDES:

- Upper Totally Tubular™ Control Arms
- Lower Totally Tubular™ Control Arms
- Front Sway Bar Kit
- Rear Pro-Touring Sway Bar Kit
- Rear Lowered Leaf Springs
- Front Dual-Adjustable Coil-over Kit
- Rear Dual-Adjustable Aluminum-Body Shocks

PRO-TOURING PACKAGES

PART #	DESCRIPTION	RETAIL	JOBBER	DEALER
5557PTK-1	1955-57 Chevy Fullsize	\$1,597.00	\$1,517.00	\$1,300.00
5557PTK-2	1955-57 Chevy Fullsize	\$2,159.00	\$2,051.00	\$1,800.00
5557PTK-3	1955-57 Chevy Fullsize	\$3,299.00	\$3,199.00	\$2,899.00
5557PTK-4	1955-57 Chevy Fullsize	\$3,799.00	\$3,549.00	\$3,299.00
UPGRADES:				
CP50000-2	500 Series Steering Box, 1955-57 Chevy Fullsize	\$419.00	\$369.00	\$314.00
FBM25	Billet Sway Bar Mounts - Front, pair	\$69.00	\$48.00	\$32.00
RBM-DK	Billet Sway Bar Mounts - Rear, Deluxe kit	\$129.00	\$115.00	\$90.00

UPGRADES AVAILABLE!

500Series™

14:1 SPORT RATIO POWER STEERING GEAR BOXES

#CP50000-2



BILLET ALUMINUM SWAY BAR MOUNTS

AVAILABLE IN BRUSHED, POLISHED, & BLACK FINISH!

#FBM25-P



#RBM-DK-B

1955-57 CHEVY FULLSIZE

PTK-3 KIT INCLUDES:

- Upper Totally Tubular™ Control Arms
- Lower Totally Tubular™ Control Arms
- Front Sway Bar Kit
- Rear Pro-Touring Sway Bar Kit
- Rear Lowered Leaf Springs
- Front Dual-Adjustable Coil-over Kit
- Rear Dual-Adjustable Aluminum-Body Shocks
- +** Complete 11" Front & 11" Rear Stock Height Disc Brake Kit with Upgraded Drilled & Gas-slotted Rotors
- Chrome Master Cylinder with Adjustable Prop Valve Distribution Block

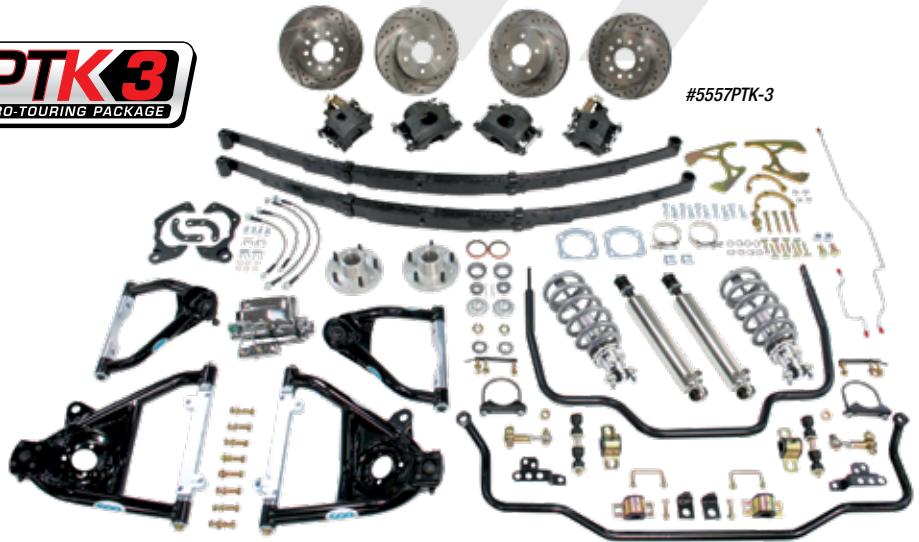

#5557PTK-3



#5557PTK-4



1955-57 CHEVY FULLSIZE

PTK-4 KIT INCLUDES:

- Front Upper Totally Tubular Control Arms
- Front Lower Totally Tubular Control Arms
- Front Sway Bar Kit
- Rear Pro-Touring Sway Bar Kit
- Rear Lowered Leaf Springs
- Front Dual-Adjustable Coil-over Kit
- Rear Dual-Adjustable Aluminum-Body Shocks
- +** Complete 13" Front & 12" Rear Stock Height Big Brake Kit w/ Drilled & Gas-slotted Rotors
- Chrome Master Cylinder with Adjustable Prop Valve Distribution Block



COMPLETE LINE OF 1955-57 CHEVY TRI-FIVE UPGRADE PACKAGES AVAILABLE!

COMING SOON!

1955-57 CHEVY TRI-FIVE FRAME SHOWN



Classic Performance Products, Inc.

SUSPENSION / COIL-OVER SYSTEMS

SCAN QR CODE TO SEE
HOW OUR COIL-OVER KIT
HANDLES ON THE TRACK!



1970 CAMARO



COMPLETE CLASSIC FIT COIL OVER SYSTEM

CPP now offers a complete front and rear coil-over systems for your classic car or truck. Each kit includes a bolt-on front coil-over system that includes high-quality dual-adjustable shocks, specially designed conical springs and all mounting hardware. We offer different Stages of rear suspension options to cater to your budget or driving environment! Both front and rear shock bodies are made of high-quality billet aluminum, featuring dual 19-click rebound and compression adjustment knobs providing an amazing total of 361 possible dampening combinations. The threaded body allows ride height adjustment and shock compression/rebound adjustments.

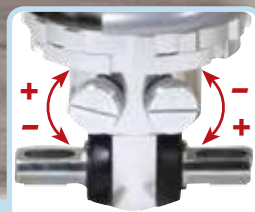

INDEPENDENTLY TUNE
COMPRESSION &
REBOUND WITH OUR
DUAL ADJUSTABLE
SHOCKS

STAGE 1: FRONT DUAL-ADJUSTABLE COIL-OVER KIT

KIT FEATURES*

- Front Dual-adjustable shocks
- Specially designed conical springs
- Mounting hardware



#6467COK-

STAGE 2: FRONT DUAL-ADJUSTABLE COIL-OVER KIT WITH UPPER & LOWER CONTROL ARMS

KIT FEATURES*

- Totally Tubular Upper & Lower Control Arms
- Front Dual-adjustable shocks
- Specially designed conical springs
- Mounting hardware

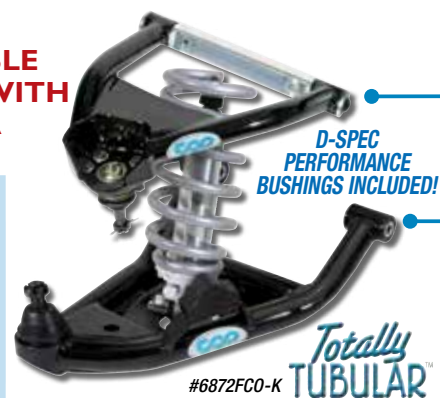

D-SPEC
PERFORMANCE
BUSHINGS
INCLUDED!

Totally
TUBULAR™

#6872FCO-K

PART #	DESCRIPTION	RETAIL	JOBBER	DEALER
6387COK-	1963-87 Chevy Truck	\$799.00	\$719.00	\$619.00
6470COK	1964-66 Mustang	\$449.00	\$417.00	\$395.00
6470COK	1967-70 Mustang	\$449.00	\$417.00	\$395.00
5564COK-2A-	1958-64 Fullsize	\$449.00	\$417.00	\$395.00
6267COK-2A350	1962-67 Nova	\$449.00	\$417.00	\$395.00
6774COK-	1968-74 Nova	\$449.00	\$417.00	\$395.00
6774COK-	1967-69 Camaro	\$449.00	\$417.00	\$395.00
7081COK-	1970-81 Camaro	\$449.00	\$417.00	\$395.00
6467COK-	1964-67 Chevelle	\$449.00	\$417.00	\$395.00
6872COK-	1968-72 Chevelle	\$449.00	\$417.00	\$395.00
7887COK	1978-87 G-Body	\$449.00	\$417.00	\$395.00
M2COK-	Mustang 2	\$449.00	\$417.00	\$395.00

PART#	DESCRIPTION	RETAIL	JOBBER	DEALER
6387FCO-K-	1963-72 Chevy Truck	\$1,599.00	\$1,439.00	\$1,219.00
6466FCO-K	1964-66 Mustang	\$1,149.00	\$1,029.00	\$879.00
6770FCO-K	1967-70 Mustang	\$1,149.00	\$1,029.00	\$879.00
5557FCO-K	1955-57 Fullsize	\$1,269.00	\$1,149.00	\$1,009.00
5864FCO-K	1958-64 Fullsize	\$1,309.00	\$1,179.00	\$999.00
6267FCO-K	1962-67 Nova	\$1,149.00	\$1,029.00	\$879.00
6774FCO-K	1967-69 Camaro, 1968-74 Nova	\$1,179.00	\$1,059.00	\$929.00
7081FCO-K	1970-81 Camaro	\$1,179.00	\$1,059.00	\$929.00
6467FCO-K	1964-67 Chevelle	\$1,179.00	\$1,059.00	\$929.00
6872FCO-K	1968-72 Chevelle	\$1,179.00	\$1,059.00	\$929.00
7887FCO-K	1978-87 G-Body	\$1,149.00	\$1,029.00	\$879.00
EM2SO-B2A	Mustang II	\$479.00	\$409.00	\$429.00

FRONT DUAL-ADJUSTABLE COIL-OVER UPGRADE

Already have a CPP Tubular Control arm kit or one of our Mustang II suspensions installed with traditional coil springs? If you are considering adding coil overs, these kits are designed specifically for C-10 (1963-87) and all Mustang II Applications requiring different or modified lower Tubular arm. These will make this a complete bolt on application. Kits include dual-adjustable coil over kits like offered above.

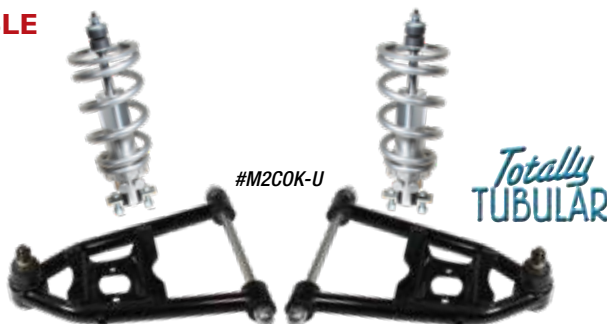

#M2COK-U

Totally
TUBULAR™

PART #	DESCRIPTION	RETAIL	JOBBER	DEALER
6387FCO-LK	1963-72 Chevy Truck	\$1,299.00	\$1,169.00	\$995.00
M2COK-U	Mustang II	\$649.00	\$599.00	\$540.00





1970 CHEVY C10

STAGE 4: FRONT DUAL-ADJUSTABLE COIL-OVER KIT WITH UPPER & LOWER CONTROL ARMS & REAR DUAL ADJUSTABLE SHOCKS

This front and rear system will create a full 4-corner, height-adjustable suspension as well as fine tuning compression and rebound adjustments for your desired road-feel.

KIT FEATURES*

- Totally Tubular Upper and Lower Control Arms
- Front Dual-adjustable shocks
- Specially designed conical springs
- Mounting hardware
- Rear dual-adjustable shocks for leaf spring or coil spring applications



#6874DASK



#6872CDAK

STAGE 3: FRONT DUAL-ADJUSTABLE COIL-OVER KIT WITH REAR DUAL-ADJUSTABLE SHOCKS

This front and rear system will create a full 4-corner, height-adjustable suspension as well as fine tuning compression and rebound adjustments for your desired road-feel.

KIT FEATURES*

- Front Dual-adjustable shocks
- Specially designed conical springs
- Mounting hardware
- Rear dual-adjustable shocks for leaf spring or coil spring applications

PART #	DESCRIPTION	RETAIL	JOBBER	DEALER
6466DASK	1964-66 Mustang	\$799.00	\$749.00	\$709.00
6770DASK	1967-70 Mustang	\$799.00	\$749.00	\$709.00
5564DASK	1958-64 Fullsize	\$799.00	\$749.00	\$709.00
6267DASK	1962-67 Nova	\$799.00	\$749.00	\$709.00
6874DASK	1968-74 Nova	\$799.00	\$749.00	\$709.00
6769DASK	1967-69 Camaro	\$799.00	\$749.00	\$709.00
7081DASK	1970-81 Camaro	\$799.00	\$749.00	\$709.00
6467DASK	1964-67 Chevelle	\$799.00	\$749.00	\$709.00
6872DASK	1968-72 Chevelle	\$799.00	\$749.00	\$709.00
7887DASK	1978-87 G-Body	\$799.00	\$749.00	\$709.00

Totally TUBULAR™

PART #	DESCRIPTION	RETAIL	JOBBER	DEALER
6466CDAK	1964-66 Mustang	\$1,499.00	\$1,359.00	\$1,099.00
6770CDAK	1967-70 Mustang	\$1,499.00	\$1,359.00	\$1,099.00
5557CDAK	1955-57 Fullsize	\$1,619.00	\$1,479.00	\$1,329.00
5864CDAK	1958-64 Fullsize	\$1,649.00	\$1,509.00	\$1,309.00
6267CDAK	1962-67 Nova	\$1,499.00	\$1,359.00	\$1,099.00
6874CDAK	1968-74 Nova	\$1,529.00	\$1,399.00	\$1,239.00
6769CDAK	1967-69 Camaro	\$1,529.00	\$1,399.00	\$1,239.00
7081CDAK	1970-81 Camaro	\$1,529.00	\$1,399.00	\$1,239.00
6467CDAK	1964-67 Chevelle	\$1,529.00	\$1,399.00	\$1,239.00
6872CDAK	1968-72 Chevelle	\$1,529.00	\$1,399.00	\$1,239.00
7887CDAK	1978-87 G-Body	\$1,569.00	\$1,459.00	\$1,359.00



FRONT AND REAR DUAL-ADJUSTABLE COIL-OVER UPGRADE KITS

This front and rear system will create a full 4-corner, height-adjustable suspension as well as fine tuning compression and rebound adjustments for your desired road-feel. Kit includes front dual-adjustable shocks, specially designed conical springs, mounting hardware, rear dual-adjustable shocks specially designed springs and all mounting brackets specific to Chevy C10 trucks and Chevelles.

STAGE 3

PART #	DESCRIPTION	RETAIL	JOBBER	DEALER
6372DACOK	1963-72 Chevy Truck	\$1,498.00	\$1,349.00	\$1,179.00
6467DACOK	1964-67 Chevelle	\$999.00	\$949.00	\$859.00
6872DACOK	19 68-72 Chevelle	\$999.00	\$949.00	\$859.00

STAGE 4

PART #	DESCRIPTION	RETAIL	JOBBER	DEALER
6372CDACOK	1963-72 Chevy Truck	\$2,289.00	\$2,069.00	\$1,769.00
6467CDACOK	1964-67 Chevelle	\$1,749.00	\$1,589.00	\$1,389.00
6872CDACOK	1968-72 Chevelle	\$1,749.00	\$1,589.00	\$1,389.00

STAGE 4+: REAR TRAILING ARM & COIL-OVER KIT

Our rear full suspension kits are available for the always popular 1963-72 C10 trucks. Our C-10 kit includes trailing arm drop crossmember, trailing arms, coil-overs and upper shock crossmember. Available in 0-3 and 3-5" of height adjustment with full compression and rebound adjustment of the shocks.

PART #	DESCRIPTION	RETAIL	JOBBER	DEALER
6372RCO-K	1963-72 Chevy Truck	\$1,299.00	\$1,169.00	\$999.00



#6372RCO-K

Drop Center Crossmember, Carrier Bearing, Rear Shock Crossmember, C-Notch Kit, U-Bolts, Axles Seats and Drop Blocks are available separately.

Classic Performance Products, Inc.

SUSPENSION / ACTIVE SHOCK MANAGEMENT

UPPER CONTROL ARM SHAFT KITS FOR 1970-73 CAMARO

OEM replacement for this high wear item kit includes two shafts with grease seals, end caps and a choice of rubber or poly bushings. For 1970-73 Camaro applications.



PART #	DESCRIPTION	RETAIL	JOBBER	DEALER	PART #	DESCRIPTION	RETAIL	JOBBER	DEALER
CP9009-RK	Upper Cross Shafts w/ Rubber Bushings, kit	\$55.00	\$49.00	\$38.00	CP9009-R	Shaft with Rubber Bushings, ea.	\$29.00	\$24.00	\$19.00
CP9009-PK	Upper Cross Shafts w/ POLYPLUS Bushings, kit	\$89.00	\$79.00	\$66.00	CP9009-P	Shaft with Polyplus bushings, ea	\$49.00	\$39.00	\$33.00



1967 CAMARO

SCAN QR CODE TO SEE
CPP's Comeback Camaro

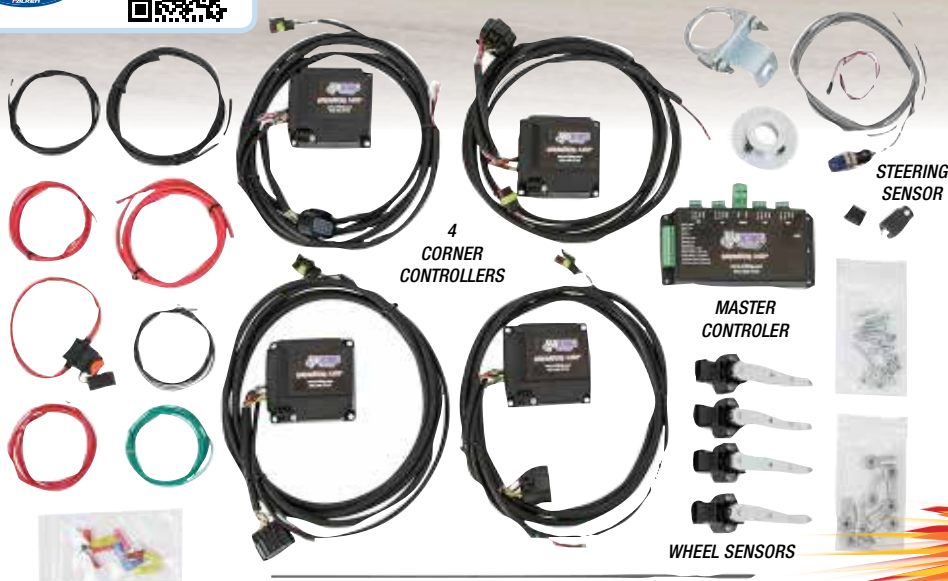

CALL US TODAY TO DESIGN YOUR PACKAGE!

BERSERKER ASM & MOUNTS

The made-in-the-USA Berserker ASM™ utilizes hydraulic shocks with computer-controlled, electrically actuated valving. This system ultra-high performance suspension control with improved ride quality, and without the need for the driver to adjust anything. The Berserker ASM™ includes a technological built-in bump stop to prevent the shocks from topping or bottoming out, and automatically adjusts to absorb potholes, speed bumps, rough terrain and so on. The system fits a variety of popular muscle car and hot rod vehicles, and it is also available in universal lengths and mounts. Depending on application, the shock valves are either remote mounted for clearance around chassis and suspension components, or piggybacked onto the shock body. In addition to all of the wiring, terminals, connectors, relays, fuses, switches, fasteners, brackets, hardware, and spanner wrenches, the kit also includes the following: Steering Sensor, Corner Controllers, Hide Height Sensors and Master Controller.

Viking Performance
Berserker ASM
Tuning Tool

APPLICATIONS:

- All Popular Applications

COMPLETE KIT FEATURES*



- **Upper & Lower OE-Style Control Arms**
Fully Assembled with Ball Joints, Cross Shafts & Rubber Bushings. With black semi-gloss painted finish.

- **Stock Height or Dropped Front Coil Springs**

High quality OE fit with black powdercoated finish.



- **Classic Fit™**

Performance Gas Shocks
180 PSI nitrogen gas cylinder. Available for stock or drop height.

- **Stock Height Spindles**

Get back to stock height. Spindle change may require other brake components.



- **Idle Arm**

Provides a smoother, safer ride. (Upgraded Idle Arm with Roller Bearing available for 1955-57.)

- **Steering Arms**

(1958-64 Fullsize Chevy kits do NOT include steering arms.)



- **Inner & Outer Tie Rod Ends**

- **Tie Rod Adjusting Sleeves**

Your direct connection between inner and outer tie rods. These allow adjustment proper wheel alignment.

- **Manual Steering Pitman Arm**

Replaces that worn original and takes the chance of play out of the steering.

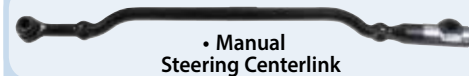

- **Manual Steering Centerlink**

UPGRADES AVAILABLE!



CPP POLYPLUS™ PERFORMANCE CONTROL ARM BUSHINGS



Engineered for superior performance, formulated to prevent squeaking, and long-lasting protection.



400Series™ & 500Series™ SPORT RATIO POWER STEERING GEAR BOXES

BOLT-ON MAXIMUM PERFORMANCE!



1955-57 CHEVY FULLSIZE

NEW! COMPLETE KITS



1967-69 CAMARO

#6769CFSR-K

COMPLETE FRONT SUSPENSION REBUILD KITS

Get everything you need to completely rebuild your front suspension in your classic. Works with applications utilizing a power steering gear box.

PART #	DESCRIPTION	RETAIL	JOBBER	DEALER
5557CFSR-K	1955-57 Chevy Fullsize, kit	\$1099.00	\$989.00	\$819.00
5860CFSR-K	1958-60 Chevy Fullsize, kit	\$1099.00	\$989.00	\$819.00
6164CFSR-K	1961-64 Chevy Fullsize, kit	\$1099.00	\$989.00	\$819.00
6267CFSR-K	1962-67 Nova, kit	\$1299.00	\$1189.00	\$1019.00
70CFSR-K	1970 Nova, kit	\$1099.00	\$989.00	\$819.00
7174CFSR-K	1971-74 Nova, kit	\$1099.00	\$989.00	\$819.00
6769CFSR-K	1967-69 Camaro, 1968-69 Nova, kit	\$1099.00	\$989.00	\$819.00
6466CFSR-K	1964-66 Chevelle, kit	\$1299.00	\$1189.00	\$1019.00
67CHCFSR-K	1967 Chevelle, kit	\$1299.00	\$1189.00	\$1019.00
6870CFSR-K	1968-70 Chevelle, kit	\$1299.00	\$1189.00	\$1019.00
7172CFSR-K	1971-72 Chevelle, kit	\$1299.00	\$1189.00	\$1019.00

Notes: 1958-60 kits use 1963-64 idler arm, pitman arm and centerlink and includes the idler arm conversion bracket. 1958-64 kits do NOT include steering arms. *Kit contents and prices may vary between certain applications.

HIGH CLEARANCE FRONT SWAY BARS

CPP's new High Clearance sway bar features a precision laser cut 3/8" leg that fits tight to the chassis allowing for significantly larger front tires. We use rod ends and eliminate the fixed position end link bushings often found on a traditional front sway bar that which limits the tire size. This kit includes a fully adjustable heim-joint end link setup allowing for multiple mounting positions and pre-load adjustments. The bars are hollow to reduce weight and the working portion of the bar is shorter to increase roll resistance.



#5557HCSBK

PART #	DESCRIPTION	RETAIL	JOBBER	DEALER	PART #	DESCRIPTION	RETAIL	JOBBER	DEALER
6387HCSBK	1963-87 Chevy Truck, kit	\$199.00	\$179.00	\$149.00	6769HCSBK	1967-69 Camaro, kit	\$199.00	\$179.00	\$149.00
5557HCSBK	1955-57 Chevy Fullsize, kit	\$199.00	\$179.00	\$149.00	7081HCSBK	1970-81 Camaro, kit	\$199.00	\$179.00	\$149.00



#6470ARSBK



#5557ARSBK



#7081ARSBK

REAR ADJUSTABLE PRO-TOURING SWAY BAR

CPP's new adjustable rear sway bar kits features billet ends welded to the center portion of the sway bar to allow for more clearance around the shock mounts. With some applications, the shocks would interfere with our Rear Pro-touring Sway bar kits. This new fully adjustable design will give you the benefits of our Rear Pro-Touring Sway Bar kits without more space and more roll resistance. These sway bars will fit both stock and aftermarket rear ends with a 3" axle tube. Kits come complete with gloss black frame mount brackets and all the necessary hardware for an easy installation.

PART #	DESCRIPTION	RETAIL	JOBBER	DEALER
6470ARSBK	1964-70 Mustang, kit	\$199.00	\$179.00	\$149.00
5557ARSBK	1955-57 Chevy Fullsize, kit	\$199.00	\$179.00	\$149.00
6267ARSBK	1962-67 Nova, kit	\$199.00	\$179.00	\$149.00
6774ARSBK	1967-69 Camaro, 1968-74 Nova, kit	\$199.00	\$179.00	\$149.00
7081ARSBK	1970-81 Camaro, kit	\$199.00	\$179.00	\$149.00
6472ARSBK	1964-72 A-Body, kit	\$199.00	\$179.00	\$149.00
7887ARSBK	1978-87 G-Body, kit	\$199.00	\$179.00	\$149.00



#6472ARSBK

REAR PRO-TOURING SWAY BAR KITS

Our rear adjustable Pro-Touring-style sway bars with fully-adjustable rod-end style end-links and hollow bars improve the cornering performance and traction of your vehicle. CPP's sway bar offers an attractive and effective way to tie the frame rails together for that Pro-Touring experience. The kits include adjustable heim end-links, premium mounting hardware, laser cut frame mount brackets, greasable polyurethane bushings, grade 8 bolts and gloss black powdercoated finish. For the ultimate in looks and longevity when pounding your street machine on and off the track, upgrade to these billet sway bar mount bracket kits. They feature greasable poly bushings and are available in a brushed machine, black or polished finish. Specify finish and diameter of sway bar.



#5557PTSBK
SHOWN WITH UPGRADED
BILLET MOUNTS

UPGRADE
TO
DELUXE
MOUNTS!



#RBM-DK

PART #	DESCRIPTION	RETAIL	JOBBER	DEALER	PART #	DESCRIPTION	RETAIL	JOBBER	DEALER
6470PTSBK	1964-70 Mustang, kit	\$189.00	\$170.00	\$139.00	7081PTSBK	1970-81 Camaro, kit	\$189.00	\$170.00	\$139.00
5557PTSBK	1955-57 Fullsize, kit	\$189.00	\$170.00	\$139.00	6274PTSBK	1964-72 Chevelle, kit	\$189.00	\$170.00	\$139.00
6267PTSBK	1962-67 Nova, kit	\$189.00	\$170.00	\$139.00	7887PTSBK	1978-87 G-Body, kit	\$189.00	\$170.00	\$139.00
6774PTSBK	1967-69 Camaro, 1968-74 Nova, kit	\$189.00	\$170.00	\$139.00	RBM-DK	Deluxe Upgrade, kit	\$129.00	\$115.00	\$90.00

Note: Will not work with 9 Plus-style rear ends.



M2SBB-U
SHOWN INSTALLED

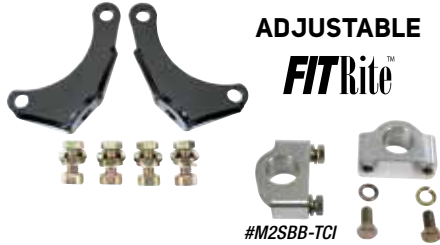

ADJUSTABLE
FITrite™

#M2SBB-TCI

MUSTANG II SWAY BAR BRACKETS

CPP has developed new sway bar brackets to accommodate any aftermarket Mustang II crossmember with our Mustang II Sway Bars. Our #M2SBB-U bracket kit will work with multiple width and end link (heim joint style) combinations. This bracket kit has been designed with adjustability in mind, to easily find the center when installing and to keep the end link straight. Our #M2SBB-TCI brackets will allow you to mount a CPP sway bar to your TCI crossmember.

PART #	DESCRIPTION	RETAIL	JOBBER	DEALER
M2SBB-U	Adjustable (w/hardware), kit	\$29.00	\$26.00	\$20.00
M2SBB-TCI	For TCI Crossmember, kit	\$25.00	\$17.00	\$14.00

Note: M2SBB-U Will not work with traditional bushing endlink.

PRO-TOURING TURN9 STYLE CURRIE REAR ENDS

Complete Currie 9" rear housing and axle kits are now available in 3 different styles. For years we have carried the traditional 9-Plus housing and axle sets and they are great, super strong and are truly top of the line. They work great in most applications but limit the type of sway bar that can be used due to the gusseted type center section. Working closely with Currie we now have a solution! We would like to introduce the Pro-Touring Turn 9 housing and Axle setups. These new housing designs will allow the use of our popular Pro-Touring rear sway bar applications! If you are looking for the top of the line, fully fabricated center section the Pro-Touring Turn 9 is a great option. Housings include 3rd member studs installed and Torino-style late model large bearing housing ends. They are complete with 31 spline axles, your choice of bolt pattern and include bearings, seals and studs already installed. Each application is built specifically with rear suspension mounts already welded to make them a direct fit for your car or truck. All rear ends are available in 35-spline axles and with 1/2" studs. Custom widths and axle bracket positions available. Call a CPP Rep to discuss options. Universal rear ends are bare axles, and do not include the spring seats or mounting brackets. Third members also available separately.

PART #	DESCRIPTION	RETAIL	JOBBER	DEALER
CHEVY TRUCK W/TRAILING ARM REAR SUSPENSION				
GMC6062X5-T9	1960-62, 5 lug (7/16" stud)	\$1,515.00	\$1,363.50	\$1,287.75
GMC6062X6-T9	1960-62, 6 lug (7/16" stud)	\$1,515.00	\$1,363.50	\$1,287.75
GMC6370X5-T9	1963-70 C10 (62" hub to hub) 5 lug (1/2" stud)	\$1,515.00	\$1,363.50	\$1,287.75
GMC6370X6-1/2-T9	1963-70 C10 (62" hub to hub) 6 lug (7/16" stud)	\$1,515.00	\$1,363.50	\$1,287.75
GMC7072X5-T9	1970-72 C10, late, (63-5/8" hub to hub) 5 lug (1/2" stud)	\$1,515.00	\$1,363.50	\$1,287.75
GMC7387X5-T9	1970-87 C10 (63-5/8" hub to hub) 5 lug (1/2" stud)	\$1,514.80	\$1,439.00	\$1,364.00
GMC7387X6-T9	1970-87 C10 (63-5/8" hub to hub) 6 lug (7/16" stud)	\$1,514.80	\$1,439.00	\$1,364.00
GMT7387X6-1/2-T9	1970-87 C10 (63-5/8" hub to hub), 6-lug (1/2" stud)	\$1,514.80	\$1,439.00	\$1,364.00

CHEVY FULLSIZE

GMB5557X-T9	1955-57, 7/16" stud	\$1,494.00	\$1,344.60	\$1,269.90
GMB5557X-1/2-T9	1955-57, 1/2" stud	\$1,494.00	\$1,344.60	\$1,269.90
GMB5557X-LRK-T9	1955-57 *	\$1,494.00	\$1,344.60	\$1,269.90
GMB5557X-MT-LRK-T9	1955-57, for wheel tubs *	\$1,494.00	\$1,344.60	\$1,269.90

Note: GMB5557-LRK is for vehicles with rear shock relocation kit.



UNIVERSAL ROD END LINK ADAPTER

This bolt on adapter features a rod end (heim-joint) to replace the rubber bushings on the sway bar end links, making for a much firmer sway bar by eliminating a large amount of flex and play that occurs in traditional end links. This will allow your vehicle to respond quicker, with more accuracy and consistency. Kit includes high quality heim-joints, steel brackets and all mounting hardware.

PART #	DESCRIPTION	RETAIL	JOBBER	DEALER
CP12176	kit	\$65.00	\$57.00	\$49.00



PART #	DESCRIPTION	RETAIL	JOBBER	DEALER
CAMARO & NOVA				
GMF6769MX-T9	1967-69 Camaro & 1968-74 Nova w/multi-leaf, 7/16" stud	\$1,577.00	\$1,401.30	\$1,323.45
GMF6769MX-1/2-T9	1967-69 Camaro & 1968-74 Nova w/multi-leaf, 1/2" stud	\$1,577.00	\$1,401.30	\$1,323.45
GMF6769SX-T9	1967-69 Camaro & 1968-74 Nova w/mono-leaf, 7/16" stud	\$1,577.00	\$1,401.30	\$1,323.45
GMF6769SX-1/2-T9	1967-69 Camaro & 1968-74 Nova w/mono-leaf, 1/2" stud	\$1,577.00	\$1,401.30	\$1,323.45
GMF7081X-T9	1970-1/2 - 81 Camaro w/multi-leaf, 7/16" stud	\$1,577.00	\$1,401.30	\$1,323.45
GMN6367MX-T9	1963-67 Nova w/multi-leaf, 7/16" stud	\$1,577.00	\$1,401.30	\$1,323.45
GMN6367SX-T9	1963-67 Nova w/mono-leaf, 7/16" stud	\$1,577.00	\$1,401.30	\$1,323.45
GMN6367SX-1/2-T9	1963-67 Nova w/mono-leaf, 1/2" stud	\$1,577.00	\$1,401.30	\$1,323.45
CHEVELLE, EL CAMINO, MONTE CARLO				
GMA6466X-T9	1964-66, 7/16" stud	\$1,702.00	\$1,531.80	\$1,446.70
GMA6466X-1/2-T9	1964-66, 1/2" stud	\$1,702.00	\$1,531.80	\$1,446.70
GMA67XL-T9	1967, 7/16" stud	\$1,702.00	\$1,531.80	\$1,446.70
GMA6872X-T9	1968-72, 7/16" stud	\$1,702.00	\$1,531.80	\$1,446.70
GMA6872X-1/2-T9	1968-72, 1/2" stud	\$1,702.00	\$1,531.80	\$1,446.70
G-BODY				
GMG7887X-T9	1978-87, 12mm stud	\$1,702.00	\$1,531.80	\$1,446.70



STREET-TRAC™ TRACTION BARS

CPP's new Street-Trac™ traction bars - where the power meets the road! Constructed from 1" 0.156-wall 4130 (same as our Pro-Touring sway bar), with 3/16" laser-cut, bent-steel mounts and self-lubricating plastic D-type bushings (same as used in our control arms) and 3/4" rod ends. The front mount features additional ground clearance and a forward-slanted approach angle. In the event it does hit something, the angled approach will act as a skid plate and help lift the car over the obstacle. The portion of the linkage that contacts the spring is a wider flat surface; this reduces the stress on the top of the leaf spring. The pivot positions are relocated to optimize weight transfer while reducing the spring load.

PART #	DESCRIPTION	RETAIL	JOBBER	DEALER
5557TB	1955-57 Fullsize	\$299.00	\$269.00	\$225.00
6473TB	1964-73 Ford Mustang, for stock axle, kit	\$299.00	\$269.00	\$225.00
6473TB-L	1964-73 Ford Mustang, for 2" or 3" lowering blocks, kit	\$299.00	\$269.00	\$225.00
6473TB-R	1964-73 Ford Mustang, for reversed eye applications with stock axle, kit	\$299.00	\$269.00	\$225.00
6473TB-RL	1964-73 Ford Mustang, for reversed eye applications with 2" or 3" lowering blocks kit	\$299.00	\$269.00	\$225.00
6281TB-S	1962-74 Nova, 1967-81 Camaro, stock axle applications	\$299.00	\$269.00	\$225.00
6274TB-L	1962-74 Nova, 1967-69 Camaro, for applications using lowering blocks	\$299.00	\$269.00	\$225.00
7081TB-L	1970-81 Camaro, for applications using lowering blocks	\$299.00	\$269.00	\$225.00



X-FRAME BRACE FOR MUSTANG

Use in combination with CPP Subframe Connectors for added strength and stability. Comes with a black powdercoated finish.

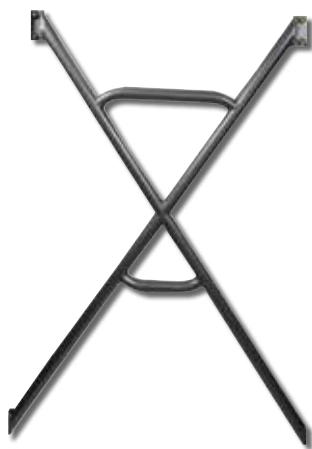

PART #	DESCRIPTION	RETAIL	JOBBER	DEALER
6470XFB-KB	1964-72 Mustang, kit	\$299.00	\$270.00	\$219.00



SUBFRAME CONNECTORS

CPP introduces their brand new connectors made using round tubing with 1.5" od x .120 wall. Round tube resists torsional twist better than square tube versions and also provide for maximum ground clearance. The connectors are 100% bolt in and include all mounting hardware. Subframe connectors provide resistance to chassis flex and therefore increase the integrity and rigidity of the chassis and are a must for any performance application. Comes in black powdercoated finish.

PART #	DESCRIPTION	RETAIL	JOBBER	DEALER
6267SFC-B	1962-67 Nova, kit	\$220.00	\$199.00	\$172.00
6769SFC-B	1967-69 Camaro, kit	\$220.00	\$199.00	\$172.00
7081FC-B	1970-81 Camaro, kit	\$169.00	\$155.00	\$135.00
6470SFC-B	1964-70 Ford Mustang, kit	\$169.00	\$155.00	\$135.00



DELUXE TRAC BAR BRACKET

Certain C10 and C20 frames have the frame bracket in a different location and this bolt-on bracket will allow you to install our deluxe trac bar kit with ease.

PART #	DESCRIPTION	RETAIL	JOBBER	DEALER
CP12173	1960-72 C10 & C20, kit	\$23.00	\$20.00	\$17.00

SHOCK TOWER BRACE KIT

CPP's Shock Tower Brace Kit strengthens and improves chassis rigidity and overall vehicle handling. No drilling and no welding. The one piece mounting bracket on each shock tower also attaches to the inner fender structure. This braces the fender and shock tower together. Then the one piece mount also attaches the cross bar and triangulated style fire wall braces. The firewall braces have 1/4" steel both above and below the firewall flange. This steel sandwich captures all 4 firewall bolts while providing a rigid mount for the rear braces. More rigidity and less hardware than a traditional Monte Carlo bar and export brace. Rod ends provide an adjustable attachment to ensure a perfect fit every time. Comes with a black powdercoat finish.

PART #	DESCRIPTION	RETAIL	JOBBER	DEALER
6466STB-BK	1964-66 Mustang, kit	\$189.00	\$173.00	\$139.00





1964-72 FORD MUSTANG REAR LEAF SPRINGS
Kits work with traditional 3" axle tubes commonly found with 8 and 9" Ford rear ends. Assembled with teflon buttons for a smooth quiet ride. Springs yield a 2" drop.

PART #	DESCRIPTION	RETAIL	JOBBER	DEALER
6573RLS-D	1964-73 Mustang, pr.	\$399.00	\$359.00	\$319.00

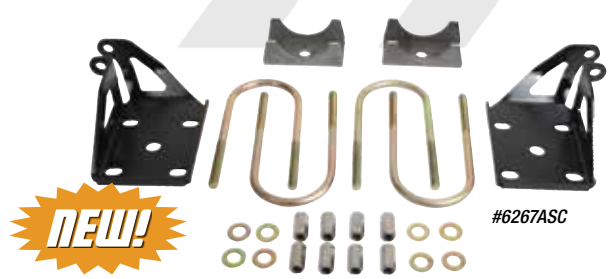

AXLE SEAT CONVERSION KIT

This kit is used to convert from Mono to Multi-leaf springs for 1962-74 Nova as well as 1967-69 Camaro. Kit features Axle seats, U-bolts and hardware and lower shock plates. This kit will eliminate the use of factory studs through the rear end perch and stock leaf spring pads. With a full U-bolt around the axle making the rear end more connected to the car than ever. Perfect for rear end conversions with a 3" axle tube common on most 10-12 bolt GM as well as the popular 9" fords.



PART #	DESCRIPTION	RETAIL	JOBBER	DEALER
6267ASC	1962-67 Nova & 1967 Camaro, kit	\$129.00	\$115.00	\$99.00
6874ASC	1968-74 Nova, 1968-69 Camaro, kit	\$129.00	\$115.00	\$99.00



AXLE TIE PLATES

This fits 3" axle tubes for stem mounted shocks. This is needed for 1965-66 Mustangs that had a 2-1/4" axle tube that are being updated to a 3" tube like a regular Ford 9" axle. The kit is a pair of tie plates, and a set of U-bolts. It can be used with conventional lowering blocks.



PART #	DESCRIPTION	RETAIL	JOBBER	DEALER
6573TP	1964-73 Mustang, kit	\$69.00	\$65.00	\$54.00



HIGH PERFORMANCE REAR SHACKLE KITS

This shackle is ideal for anyone that wants to drive their car harder, or run a larger tire. The design prevents the shackles and bushings from flexing side to side. They use D-spec bushings and steel pivot sleeves. The steel sleeves allow the shackles to become completely tight on the pivots with a precision fit to the spring and chassis. The OE and poly bushings are simply tightened, deforming the bushing, creating friction, and allow the spring to move side to side. The shackle is formed with a C-section to increase its side to side strength. These have virtually no deflection allowing you to confidently fit wider tires even closer to the fenders.



PART #	DESCRIPTION	RETAIL	JOBBER	DEALER
6473SHK-RE	1964-73 Mustang, kit	\$89.00	\$76.00	\$66.00
6267SHK-RE	1962-67 Nova, kit	\$89.00	\$76.00	\$66.00
6781SHK-RE	1967-81 Camaro, 1968-74 Nova, kit	\$89.00	\$76.00	\$66.00



OFFSET SHACKLE KITS

These bolt in and reposition the rear of the spring allowing more room to fit wider rear tires. The 3/4" offset works with the original fuel tank. The 1-3/4" offset requires a narrower fuel tank.

PART #	DESCRIPTION	RETAIL	JOBBER	DEALER
6774OSS-75	1967-69 Camaro, 1968-74 Nova, 3/4" offset, kit	\$139.00	\$126.00	\$109.00
6774OSS-175	1967-69 Camaro, 1968-74 Nova, 1-3/4" offset, kit	\$159.00	\$144.00	\$129.00

Classic Performance Products, Inc.

SUSPENSION / NARROW LEAF SPRING UPGRADE KITS



SCAN QR CODE:

View the install of this kit & more CPP items on the Muscle Car Challenge 1970 Camaro!



COMPLETE NARROW LEAF SPRING UPGRADE KITS

Our new CPP Narrow leaf spring upgrade kits are available for 1967-81 Camaros and 1962-74 Novas. These kits allow for the absolute largest wheel and tire to be used without relocating the leaf springs front and rear hangers inboard. No cutting and welding on the frame rails. Kits include a custom narrowed axle bracket to match the narrowed leaf perfectly. These kits will gain you 1/2" additional tire clearance per side. Kits will fit original rear ends or any aftermarket 3" tube style 10/12 bolt or 9" ford. Great upgrade for any street, strip or Pro-Touring performer.

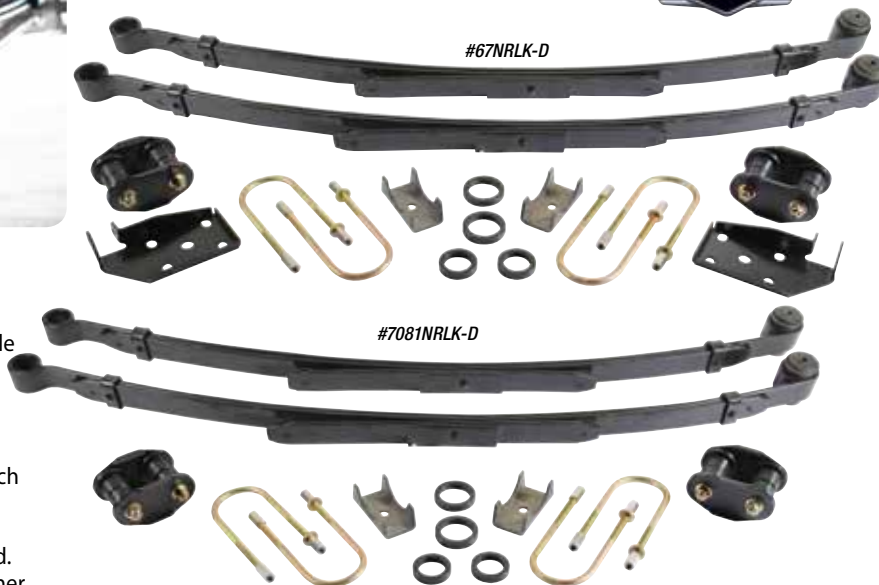

KITS FEATURE*

- (2) Multi-Leaf Springs (Stock Height Or 2" Drop)
- Weld-on Axle Brackets
- U-Bolt Set
- Spring Tie Plates (on 1967-69 Camaro & 1968-74 Nova)
- High Performance Rear Shackle Kits
- All Hardware For Easy Installation

PART #	DESCRIPTION	RETAIL	JOBBER	DEALER
6267NRLK-S	1962-67 Nova, stock, kit	\$599.00	\$527.00	\$431.00
6267NRLK-D	1962-67 Nova, 2" drop, kit	\$599.00	\$527.00	\$431.00
67NRLK-S	1967 Camaro, stock, kit	\$599.00	\$527.00	\$431.00
67NRLK-D	1967 Camaro, 2" drop, kit	\$599.00	\$527.00	\$431.00
6874NRLK-S	1968-69 Camaro & 1968-74 Nova, stock, kit	\$599.00	\$527.00	\$431.00
6874NRLK-D	1968-69 Camaro & 1968-74 Nova, 2" drop, kit	\$599.00	\$527.00	\$431.00
7081NRLK-S	1970-81 Camaro, stock, kit	\$599.00	\$527.00	\$431.00
7081NRLK-D	1970-81 Camaro, 2" drop, kit	\$599.00	\$527.00	\$431.00

UPGRADES AVAILABLE!



#CP2032



REAR LOWERING BLOCK KITS & U-BOLTS

AVAILABLE FOR ALL MODELS

PART #	DESCRIPTION	RETAIL	JOBBER	DEALER
CP2031	1" drop kit	\$39.00	\$34.00	\$31.00
CP2032	2" drop kit	\$40.00	\$36.00	\$31.00
CP2033	3" drop kit	\$42.00	\$38.00	\$31.00

UPGRADES AVAILABLE!

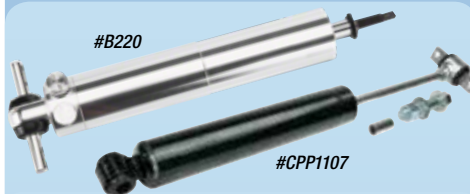

#B220

#CPP1107

STOCK MOUNT SHOCK OPTIONS

PART #	DESCRIPTION	RETAIL	JOBBER	DEALER
CPP-1105	1962-67 Nova, 1967-69 Camaro, rear stock, ea.	\$39.00	\$33.00	\$29.00
CPP-1105CM	1967-69 Camaro, with shock tab kit, ea.	\$39.00	\$33.00	\$29.00
CPP-1106	1970-78 Camaro, rear stock, ea.	\$39.00	\$33.00	\$29.00
CPP-1107	1968-74 Nova, 1967-69 Camaro, rear stock, ea.	\$39.00	\$33.00	\$29.00
B220	1968-74 Nova, dual adj. shock, ea.	\$159.00	\$143.00	\$129.00
B222	1962-67 Nova, 1967-69 Camaro, dual adj. shock, ea.	\$159.00	\$143.00	\$129.00
B205	1970-81 Camaro, dual adj. shock, ea.	\$159.00	\$143.00	\$129.00

UPGRADES AVAILABLE!

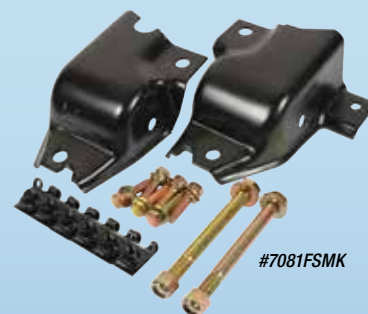

#7081FSMK

FRONT LEAF SPRING HANGER KITS

PART #	DESCRIPTION	RETAIL	JOBBER	DEALER
6774FSMK	1968-74 Nova, 1967-69 Camaro, kit	\$89.00	\$79.00	\$72.00
7081FSMK	1970-81 Camaro, kit	\$99.00	\$89.00	\$82.00

REAR SUSPENSION UPGRADES



#CPRAS-K

UNIVERSAL REAR AXLE PERCH KIT



This is a simple way to install almost any rear end into a vehicle with leaf springs. Why try to remove your old welded on spring pads (seats) when you can just replace them with new ones. This makes the process simple because you have your old rear axle still intact to use as guide to position the new seats in the perfect location. This basic kit makes changing our your rear axle a pretty easy process. Kit is designed to fit 3" axle tubes with 2.25" leaf springs.



#11571K

KITS FEATURE*

- (2) Leaf Spring Axle Seats (Weld On)
- (4) U-Bolts & Hardware
- (2) U-Bolt Tie Plates
- Shock Mounts



#5557CLSRK

1955-57 CHEVY CAR REAR LEAF SPRING RELOCATION KIT

This new basic rear leaf relocation kit from CPP includes front weld-in spring pockets, rear C-notch shackle plates, upper shackle hangers, and new shackles. Shackles have been re-designed to feature our high performance D-spec bushings, sleeves, and hardware. New upper shackle mounts are CNC formed for proper fitment and alignment with the frame. Lower shock plate tucks the shock up closer to the leaf spring so fitment of our Pro-Touring rear sway bar is perfect (sold separately). Rear pocket kits moves the spring in-line with the frame to gain 3.5" of additional clearance to allow the use of up to 10" wide wheels and with the proper backspacing and about 12" tread to contact the pavement. The Complete kit includes everything included in the basic kit, plus u-bolts, nuts, lower shock plates and shock studs.



PART #	DESCRIPTION	RETAIL	JOBBER	DEALER
CPRAS-K	Rear Axle Perch, kit	\$49.00	\$43.00	\$34.00
11571K	Brackets only	\$39.00	\$33.00	\$26.00

PART #	DESCRIPTION	RETAIL	JOBBER	DEALER
5557BLSRK	1955-57 Fullsize, Basic kit	\$239.00	\$210.00	\$179.00
5557CLSRK	1955-57 Fullsize, Complete kit (shown)	\$299.00	\$270.00	\$239.00

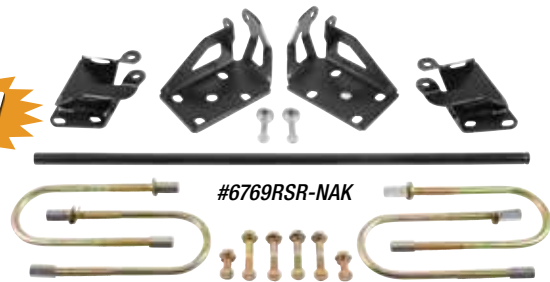

#6769RSR-NAK

REAR SHOCK RELOCATION KITS

These kits feature an adjustable crossmember upper shock mount. It bolts onto the rear of the chassis tight to the trunk floor and includes new lower shock mounts/spring tie plates. There are 4 versions to work with: original style axle perch, a narrow leaf spring, with lowering blocks, and without lowering blocks. The kit requires new shocks that mount with loop style mounts top and bottom.

PART #	DESCRIPTION	RETAIL	JOBBER	DEALER
FOR STOCK AXLE PERCH				
6769RSR-AAK	1967-69 Camaro, without lowering blocks, kit	\$299.00	\$269.00	\$239.00
6769RSR-ALK	1967-69 Camaro, with lowering blocks, kit	\$329.00	\$299.00	\$269.00
7081RSR-AAK	1970-81 Camaro, without lowering blocks, kit	\$299.00	\$269.00	\$239.00
7081RSR-ALK	1970-81 Camaro, with lowering blocks, kit	\$329.00	\$299.00	\$269.00
FOR NARROW LEAF SPRINGS				
6769RSR-NAK	1967-69 Camaro, without lowering blocks, kit	\$299.00	\$269.00	\$239.00
6769RSR-NLK	1967-69 Camaro, with lowering blocks, kit	\$329.00	\$299.00	\$269.00
7081RSR-NAK	1970-81 Camaro, without lowering blocks, kit	\$299.00	\$269.00	\$239.00
7081RSR-NLK	1970-81 Camaro, with lowering blocks, kit	\$329.00	\$299.00	\$269.00



SCAN QR CODE:
View the install of this kit & more CPP items on the WEEK TO WICKED 1972 Camaro!



Classic Performance Products, Inc.

STEERING / STEERING COLUMNS

RE-DESIGNED



#5556OSC-AK-NS

NEW!

1955-57 CHEVY CAR OE STEERING COLUMNS

CPP has re-designed its OE-style steering columns for the 1955-57 Chevy Fullsize cars! We have fitted our new columns with the proper neutral safety switch and shifter detent set-up for all common 3 & 4 speed automatics. The length has been shortened to work with our 500 Series™ power steering box, as well as older 605 and 600 style conversion boxes. Columns can use both stock and reproduction upper shifter, turn signal housing and factory shift indicator rod. Available with or without rag joint.

PART #	DESCRIPTION	RETAIL	JOBBER	DEALER
5556OSC-AK-NS	1955-56 Chevy Fullsize, ea.	\$169.00	\$149.00	\$125.00
57OSC-AK-NS	1957 Chevy Fullsize, ea.	\$169.00	\$149.00	\$125.00
5556OSC-K-RAG	1955-56 Chevy Fullsize, with rag joint, ea.	\$199.00	\$175.00	\$140.00
57OSC-K-RAG	1957 Chevy Fullsize, with rag joint, ea.	\$199.00	\$175.00	\$140.00
NS5	Neutral Safety Switch, ea.	\$20.00	\$19.00	\$18.00

Note: Requires a rag joint (#RJC-605S) if installing on a 500 Series™ power steering box or older 605 conversion box.



• Neutral safety switch pre-installed

• Lower Detent Kit

• Shift Arm



STEERING COLUMN ACCESSORIES

CPP offers all the steering column accessories to assist you with installing your new steering column!

PART #	DESCRIPTION	RETAIL	JOBBER	DEALER
CPSCA-P	Short Column Adapter, polished	\$60.00	\$54.00	\$45.00
CPSCA-C	Short Column Adapter, chrome	\$65.00	\$58.00	\$49.00
CPSCFM-C	Chrome Billet Floor Mount	\$60.00	\$52.00	\$45.00
CPCD-2	Column Drop, 2"	\$49.00	\$43.00	\$34.00
CPCD-3	Column Drop, 3"	\$49.00	\$43.00	\$34.00
CPCD-4	Column Drop, 4"	\$49.00	\$43.00	\$34.00
PART #	DESCRIPTION	RETAIL	JOBBER	DEALER
37060	Turn Signal Wiring Adapter	\$25.00	\$17.00	\$14.00
41382	Hazard Warning Adapter	\$15.00	\$13.00	\$11.00
MISC-COLSPR	Universal Column Spring/Pin Replacement	\$5.00	\$4.00	\$3.00
MISC-COLSH	Universal Column Shaft Replacement	\$7.00	\$6.00	\$4.00
ESSC-ASH	Classic Fit™ Automatic Shift Handle, kit	\$19.00	\$17.00	\$15.00
ECHCR	Horn Contact, kit	\$23.00	\$19.00	\$15.00

COLUMN MOUNTING BRACKETS

CPP's new billet aluminum column mounting bracket (#CPKCMB) allows you to install a new tilt column with a key in place your old column. This bracket works on key columns and non-key 2" diameter columns. It attaches the column to GM dash mounts. This 2-piece bracket includes a set-screw to lock the column after it's been positioned. The mount is the same bolt pattern as the popular GM dash mount used from the early 1970's. Also available is a billet aluminum mounting bracket for a 1967 Nova to allow for an aftermarket (tilt, with or without tilt or shifter) column installation.

PART #	DESCRIPTION	RETAIL	JOBBER	DEALER
CPKCMB	Mounting bracket for Key Columns, kit	\$89.00	\$79.00	\$59.00
67CMB	1967 Nova, for Key Columns, kit	\$89.00	\$79.00	\$59.00



#CPKCMB

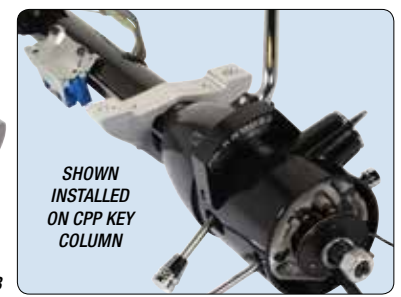

SHOWN INSTALLED ON CPP KEY COLUMN



NEW!



MIDNITE SERIES BILLET STEERING WHEEL PACKAGE

These 14" steering wheels are made from black machined aluminum for a beautiful shine. Each wheel comes with a black half wrap for the ultimate finishing touch. Our Complete Steering Wheel package includes your choice of steering wheel, a black billet horn cap, and a black steering wheel hub adapter. All for one low price! Please specify what model when ordering.

PART #	DESCRIPTION	RETAIL	JOBBER	DEALER
6794LSWB	kit	\$279.00	\$251.00	\$219.00

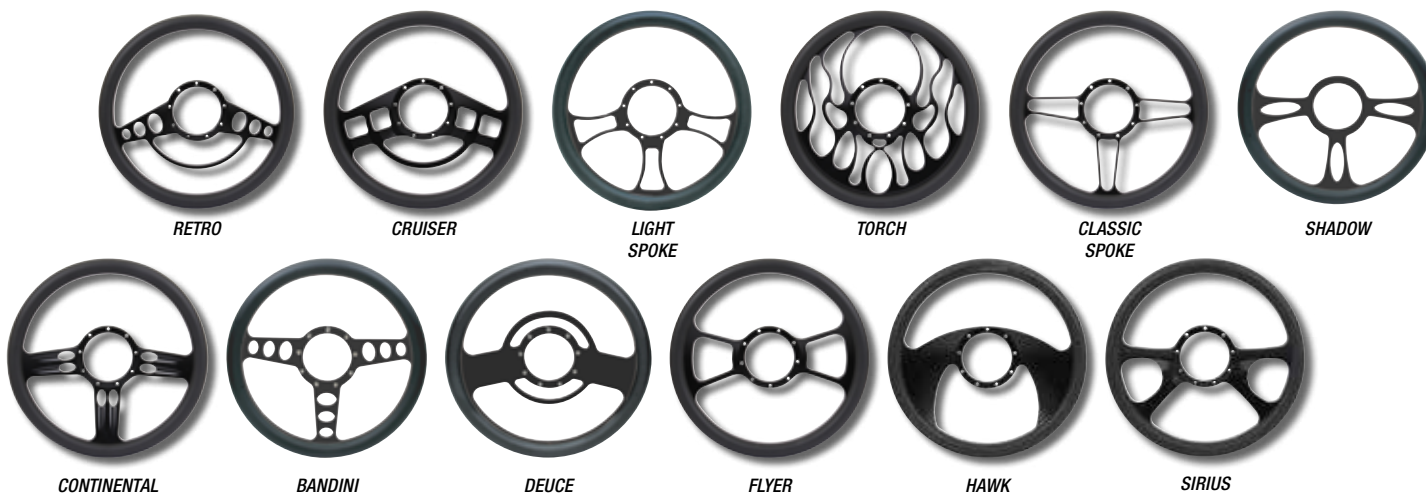

MANY CHOICES AVAILABLE!

MIDNITE SERIES BILLET STEERING WHEELS

These 14" steering wheels are made from black machined aluminum for a beautiful shine. Each wheel is comes with a black half wrap for the ultimate finishing touch. Please specify what model when ordering.

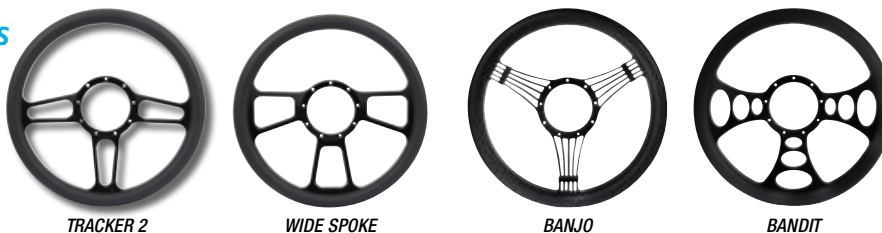

PART #	DESCRIPTION	RETAIL	JOBBER	DEALER
CPPSWB	Black rim, ea.	\$199.00	\$179.00	\$150.00

MIDNITE SERIES BILLET HORN BUTTON

Add the finishing touch to your black-billet wheel addition with our black aluminum cap. Precision machined billet aluminum for a perfect fit.

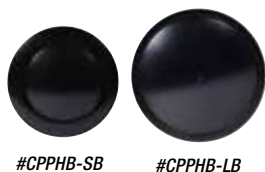

PART #	DESCRIPTION	RETAIL	JOBBER	DEALER
CPPHB-SB	Plain, each	\$39.00	\$35.00	\$27.00
CPPHB-LB	Large Plain, each	\$39.00	\$35.00	\$27.00

MIDNITE SERIES BILLET WHEEL HUB ADAPTER

For use with our black billet wheels only. Fits 1967-94 GM columns. 2" tall design.



PART #	DESCRIPTION	RETAIL	JOBBER	DEALER
6794KHB-A	1967-94 GM column, ea.	\$45.00	\$40.00	\$32.00

Note: Will not fit polished billet wheels.

Note: Will not fit polished billet wheels.



CUSTOM MINI RAG JOINTS

For that custom application running CPP's 400 Series™ or 500 Series™ box. This new small design at just over 2.5" in diameter. These are the smallest, most compact custom rag joint in the industry. Additional sizes coming soon!



PART #	DESCRIPTION	RETAIL	JOBBER	DEALER
CP59060	3/4"-36 x 3/4"-30, ea.	\$79.00	\$75.00	\$45.00
CP59065	3/4"DD x 3/4"-30, ea.	\$79.00	\$79.00	\$45.00
CP59084	1"DD x 3/4"-30, ea.	\$79.00	\$79.00	\$45.00
CP59085	1"-48 x 3/4"-30, ea.	\$79.00	\$79.00	\$45.00
CP59136	3/4"-30 x 3/4" Smooth, ea.	\$79.00	\$75.00	\$45.00
CP59129	3/4"-Smooth x 3/4"-30, ea.	\$79.00	\$79.00	\$45.00



#M2RIK

MUSTANG II RACK & PINION INSTALL KIT

When installing a manual or power rack & pinion to your crossmember, these invaluable pieces will help complete the job. Includes rubber or POLYPLUS™ bushings, spacers, bolts, washers and lock nuts.

PART #	DESCRIPTION	RETAIL	JOBBER	DEALER
M2RIK	Rubber Install kit,	\$39.00	\$35.00	\$25.00
M2PIK	POLYPLUS Install kit	\$49.00	\$44.00	\$29.00

INCLUDES!



CPP POLYPLUS™ PERFORMANCE BUSHINGS
Engineered for superior performance, formulated to prevent squeaking, and long-lasting protection.

STEERING BOX REBUILD KIT

This steering rebuild kit will allow you to rebuild your original Chevy or GMC truck steering gearbox and finally get rid of your loose or sloppy steering. If you have replaced your tie rod ends and ball joints and your classic truck still wanders when driving down the road, then it may be time to rebuild your steering box, which is one of the most overlooked yet crucial components of your suspension. This kit comes with everything you need to rebuild your steering box and upgrade it to modern tapered bearings as well. The 1947-59 kit comes with an illustrated booklet with step by step instructions taken from the original Chevrolet service manual to make the task easy to accomplish.



#6066SRK



#4759SRK

PART #	DESCRIPTION	RETAIL	JOBBER	DEALER
4759SRK	1947-59 Chevy C10/GMC 1/2-ton truck, kit	\$89.00	\$79.00	\$69.00

PART #	DESCRIPTION	RETAIL	JOBBER	DEALER
6066SRK	1960-66 Chevy C10/GMC 1/2-ton truck, kit	\$69.00	\$59.00	\$49.00



FORD POWER STEERING UPGRADE KITS

CPP has introduced our newest addition to our popular 400 Series™ line for 1964-70 Mustangs! This kit includes our 400 Series™ power steering box, pitman arm, inner and outer tie rod ends, center link and idler arm for an easy to install and complete power steering upgrade. This kit will easily fit in place of your factory manual steering box without modifying the firewall. CPP's 400 Series™ power steering box is 100% brand new, with a late model style drivability, a sportier 13.6:1 ratio (best on the market!) and a better than rack and pinion feel. The improved steering linkage kit uses components designed to help prevent bump steer.



#6466PSU-K

400Series™



PART #	DESCRIPTION	RETAIL	JOBBER	DEALER
6466PSU-KV	1964-70 Mustang w/V8 spindle, kit	\$699.00	\$629.00	\$529.00
6466PSU-KG	1964-70 Mustang w/Granada spindle, kit	\$699.00	\$629.00	\$529.00
CP50005MU	1964-70 Mustang, Power Steering box only	\$379.00	\$334.00	\$284.00



#EC6467CFIT-K



Accepts factory transfer hose/fuel neck



Fuel pump & sending unit tray comes pre-installed

COMPLETE FUEL INJECTION-READY TANK KITS

Our Complete Fuel Injection Tank Kit is the most complete choice when adding a fuel injection-ready tank to your vehicle. Our kit includes an original fit tank with built-in fuel tray, a fuel tank sending unit and a fuel regulator/filter combined with the most complete EFI fuel line kit in the market. This EFI Fuel Line Kit comes with the fuel hoses and all the fittings to plumb from the fuel pump forward. All our fuel fittings have a push lock connect end that does not require specialty tools to disassemble. Our kit also includes a 255 l/h In-tank pump That supports up to 600 HP, or an upgraded high-volume pump option, with the proper install components. In-tank pumps are much more efficient and run much cooler than running an inline pump. Contains all of the necessary pieces to mount to your vehicle.

PART #	DESCRIPTION	RETAIL	JOBBER	DEALER
FS5556CFIT-K	1955-56 Fullsize, kit	\$429.00	\$413.00	\$395.00
FS57CFIT-K	1957 Fullsize, kit	\$429.00	\$413.00	\$395.00
FS6164CFIT-K	1961-64 Fullsize, kit	\$455.00	\$413.00	\$395.00
CM6768CFIT-K	1967-68 Camaro, kit	\$480.00	\$460.00	\$438.00
CM69CFIT-K	1969 Camaro, kit	\$450.00	\$433.00	\$413.00
CM7073CFIT-K	1970-73 Camaro, kit	\$455.00	\$446.00	\$425.00
FS6566CFIT-K	1965-66 Impala, kit	\$460.00	\$438.00	\$413.00
MU6466CFIT-K	1964-66 Mustang, kit	\$455.00	\$437.00	\$417.00
MU6768CFIT-K	1967-68 Mustang, kit	\$425.00	\$409.00	\$391.00

KITS FEATURE:

* Contents may vary between applications.

- OE-Style, Fuel Injection-Ready Tank With Built-In Fuel Tray & Mounting Hardware
- Fuel Regulator/Filter
- Complete EFI Fuel Line Kit
- 255 l/h In-Tank Pump Up To 600 HP (High-Volume Also Available)
- Sending Unit

PART #	DESCRIPTION	RETAIL	JOBBER	DEALER
NV6267CFIT-K	1962-67 Nova, kit	\$455.00	\$437.00	\$417.00
NV6869CFIT-K	1968-69 Nova, kit	\$460.00	\$446.00	\$425.00
NV70CFIT-K	1970 Nova, kit	\$460.00	\$446.00	\$425.00
NV7172CFIT-K	1971-72 Nova, kit	\$460.00	\$446.00	\$425.00
MS6467CFIT-K	1964-67 Chevelle, kit	\$455.00	\$438.00	\$418.00
MS6869CFIT-K	1968-69 Chevelle, kit	\$455.00	\$437.00	\$417.00
MS70CFIT-K	1970 Chevelle, kit	\$455.00	\$437.00	\$417.00
MS7172CFIT-K	1971-72 Chevelle, kit	\$455.00	\$437.00	\$417.00
EC6467CFIT-K	1964-67 El Camino & Wagon, kit	\$425.00	\$419.00	\$400.00
EC6870CFIT-K	1968-70 El Camino, kit	\$455.00	\$437.00	\$417.00
EC7172CFIT-K	1971-72 El Camino, kit	\$455.00	\$437.00	\$417.00
GB7888CFIT-K	1978-88 Monte Carlo, kit	\$455.00	\$437.00	\$417.00
GB7888CFIT-K	1978-83 Malibu, kit	\$455.00	\$437.00	\$417.00
GN7887CFIT-K	1978-87 Grand Nat'l/Regal, kit	\$455.00	\$438.00	\$418.00



AGT-CTANK
38" x 12" x 8-1/2"
overall width: 44"



KUST-1401
27" x 17" x 9-1/4"
overall width: 44"

ECONOMY TANKS

These aluminum tanks are a must for anyone wanting move the original style tank from behind the seat to under the bed, between the frame rails. The tank comes fully baffled and is designed to work with a fuel cap on top of the bed for fuel filling. The tank comes with the fuel pick up with a -6AN fitting and an attached steel tube, and a roll over valve - that will stop gas from spilling out if the tank would happen to be upside down. There is also a preset spot for the sending unit and two ports on the bottom of the tank for fuel injection (one of the port can be plugged as well for carburetor applications).

PART #	DESCRIPTION	RETAIL	JOBBER	DEALER
AGT-CTANK	1947-54 Chevy Truck, 16-gal., each	\$299.00	\$263.00	\$229.00
AGT-ATANK	1955-59 Chevy Truck, 16-gal., each	\$299.00	\$263.00	\$229.00

PART #	DESCRIPTION	RETAIL	JOBBER	DEALER
KUST-1401	1960-72 Chevy Truck, 18-gal., each	\$299.00	\$263.00	\$229.00
AGT-BTANK	1948-60 Ford Truck, 15-gal., each	\$299.00	\$263.00	\$229.00

NEW!

FUEL PUMP INSTALL KITS

Available for our OE-style gas tanks as a drop-in setup or as a universal setup to help you convert your stock fuel tank to a new internal style pump. Running an in-tank pump has many benefits over adding an inline pump to your current system. In-tank pumps run much cooler which increases the efficiency and will greatly extend the life of your pump. These in-tank fuel pumps are also much quieter than an inline fuel pump. The large mounting flange also offers the added benefit of a fuel tray to prevent fuel starvation and are recommended for competitive applications. The large mounting flange measures 4" dia.; small measures 2-1/4" dia. Each Universal In-Tank Pump kit comes with your choice of 255LH pump up to 600 hp or 340LH pump up to 750 hp and a bracket install kit.

PART #	DESCRIPTION	RETAIL	JOBBER	DEALER
CPUPFK-	Universal Large In-Tank Pump Kit	\$175.00	\$145.00	\$130.00
UFK-FI	Bracket Install Kit for Universal Large In-Tank Pump (no pump)	\$93.00	\$79.00	\$69.00
CPFK-	Small In-Tank Pump Kit	\$165.00	\$140.00	\$120.00
FK-FI	Bracket Install Kit for Small In-Tank Pump (no pump)	\$85.00	\$72.00	\$63.00
CPHM-1	In-Tank Pump Filter, Diaper-Style, 11.75x3", ea.	\$8.00	\$7.00	\$6.00
CPHM-2	In-Tank Pump Filter, Diaper-Style, 5.25x2", ea.	\$4.00	\$3.00	\$2.00
FP-255LH	255LH pump up to 600 hp	\$89.00	\$75.00	\$66.00
FP-340LH	340LH pump up to 750 hp	\$89.00	\$75.00	\$66.00

Note: Fuel Filter/Regulator (#LS9904) will not work on 340L/h pump.



#CPUPFK

IN-TANK PUMP FILTERS

#CPHM-1

#CPHM-2

SMALL IN-TANK PUMP KIT



FK-FI TOP VIEW

INSTALLED FUEL PUMP CUT-AWAY VIEW

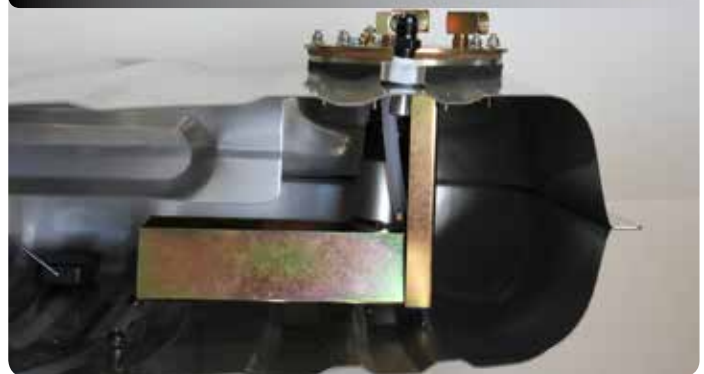

#45113 - INSTALLED TOP VIEW

#45113 - INSTALLED BOTTOM VIEW



NEW!

UNIVERSAL PUMP ADAPTER RING

#CPFPA-1

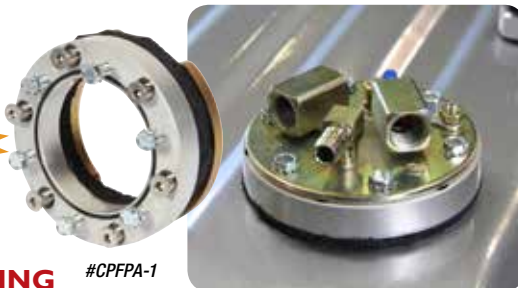

CPP's new fuel tank adapter ring mounts our small diameter fuel pump install kit. This is an easy-to-install, billet aluminum, adapter that can easily be attached to almost any fuel tank allowing our smaller fuel pump module to bolt directly. This kit features a thick, fuel safe, foam gasket to seal almost any tank. Not recommended for auto cross or racing applications.

PART #	DESCRIPTION	RETAIL	JOBBER	DEALER
CPFP-K	Adapter Ring with Bracket Install Kit for Small In-Tank Pump, kit	\$114.00	\$98.00	\$84.00
CPFPA-1	Adapter ring only, kit	\$29.00	\$26.00	\$21.00

NEW LOWERED PRICE

UNIVERSAL GAS TANK SENDING UNITS

For use with our aluminum, stainless, and zinc painted gas tanks.

PART #	DESCRIPTION	RETAIL	JOBBER	DEALER
VSU-3	0-30 ohm, ea.	\$41.00	\$34.00	\$28.00
VSU-9	0-90 ohm, ea.	\$41.00	\$34.00	\$28.00
VSU-F	73-10 ohm, ea.	\$41.00	\$34.00	\$28.00
VSU-240	240-330 ohm, ea.	\$41.00	\$34.00	\$28.00

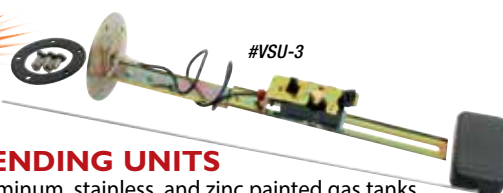

#VSU-3



#45111

#45113

UNIVERSAL FUEL TANK RETURN FITTINGS

Installing an in-line fuel pump but need to adapt a stock tank to have a return? We've got the answer. Available in both 9/16-18 inverted flare or 1/4 NPT. Simply drill a hole, install against the tank and use the supplied bolt to rivet the in-tank side in place. Works like a rivet nut insert. Super easy and clean installation. Many uses like adding a vent, power steering line return, etc. Will work on up to 1/4" thick material.

PART #	DESCRIPTION	RETAIL	JOBBER	DEALER
45113	1/4 NPT Adapter Fitting	\$17.00	\$15.00	\$12.00
45111	9/16-18 Adapter Fitting	\$17.00	\$15.00	\$12.00

NEW!



COMPLETE FUEL LINE KIT WITH FITTINGS

#LSLK Includes:

- 25 feet of Fuel Injection High-Pressure Hose
- (1) 3/8" Fuel Filter -6 Male Feed-Line Fitting
- (1) 5/16" Female Fuel Filter Return-Line Fitting
- (2) 3/8" Female To -6AN Male Straight Filter Fitting
- (2) 1/4" NPT To -6AN Male Fuel Pump Adapters
- (6) Straight -6AN Female To 3/8" Hose Fittings
- (2) 45° -6AN Female to 3/8" Hose Fittings
- (1) Fuel Filter/Regulator

EFI FUEL FILTER REGULATOR KITS

CPP now offers a EFI Fuel regulator/filter combined with the most complete EFI fuel line kit in the market. This kit comes with the fuel hoses, all the proper fittings to plumb from the fuel pump forward and regulator/filter combo. All our fuel fittings have a reusable spin lock connect end that does not require specialty tools to disassemble.

PART #	DESCRIPTION	RETAIL	JOBBER	DEALER
LSLK-F	EFI Fuel Filter/Regulator 58 psi with Complete LS Fuel Line Kit	\$129.00	\$116.00	\$96.00
LSLK	Complete EFI Fuel Line Kit	\$95.00	\$86.00	\$71.00



FUEL FITTING KITS

#LSLF9 Includes:

- (1) 3/8" Fuel Filter -6 Male Feed-Line Fitting
- (1) 5/16" Female Fuel Filter Return-Line Fitting
- (2) 3/8" Female To -6AN Male Straight Filter Fitting
- (2) 1/4" NPT To -6AN Male Fuel Pump Adapters
- (6) Straight -6AN Female To 3/8" Hose Fittings
- (2) 45° -6AN Female to 3/8" Hose Fittings



#LSLF11-K Includes:

- (2) 3/8" Fuel Filter -6 Male Feed-Line Fitting
- (1) 5/16" Female Fuel Filter Return-Line Fitting
- (1) 3/8" Male To -6AN Male Straight Filter Fitting
- (1) Fuel Filter/Regulator (shown on left)



THROTTLE BODY EFI AND CARBURETOR INSTALL ACCESSORIES

Install kit includes carburetor linkage bushings, air cleaner stud, adapters and manifold mounting studs for an easy install.

PART #	DESCRIPTION	RETAIL	JOBBER	DEALER
CPCI-K	Install Kit	\$15.00	\$13.00	\$12.00
CPCLB1	Carburetor Linkage Bushings for cable linkage	\$5.00	\$4.00	\$3.00
CPCLB2	Carburetor Linkage Bushings for mechanical linkage	\$9.00	\$8.00	\$7.00
CPACSA	Air Cleaner Adapter & Mounting Studs	\$4.50	\$4.00	\$3.00

FUEL GAUGE CONVERTER

CPP's fuel gauge interface modules solves most fuel gauge problems most encounter. This easily installs between the sender and the gauge. No need to drop tank and replace sending unit. Will match any OHM rating.



PART #	DESCRIPTION	RETAIL	JOBBER	DEALER
SG11214	kit	\$125.00	\$119.00	\$113.00



COMPACT FUEL COMMAND CENTER 2

Features a Sump Tank assembly with a 340 l/h fuel pump, regulator, pressure gauge, EFI Fuel Filter, hose and fittings.



PART #	DESCRIPTION	RETAIL	JOBBER	DEALER
FI40004	kit	\$395.00	\$375.00	\$356.00

Note: Designed to be used only with FiTech EFI Systems that include the Pulse Width Modulation (PWM) feature.





FITTINGS

These fittings can be used with fuel system and hydraulic brake assist systems. They work with traditional AN-style hoses as well as rubber hoses. Fittings available in 30, 45, 90, 120, 180 degree ends for all your custom line needs.

PART #	DESCRIPTION	RETAIL	JOBBER	DEALER
-10 AN ALUMINUM STRAIGHT FITTINGS				
C10AN12-STR	-10 AN x 1/2 Pipe Thread, ea.	\$11.00	\$9.00	\$7.00
	-10 AN x 1/2 Pipe Thread, 2-pk.	\$22.00	\$18.00	\$14.00
	-10 AN x 1/2 Pipe Thread, 6-pk.	\$59.00	\$49.00	\$39.00
C10AN38-STR	-10 AN x 3/8 Pipe Thread, ea.	\$11.00	\$9.00	\$7.00
	-10 AN x 3/8 Pipe Thread, 2-pk.	\$22.00	\$18.00	\$14.00
	-10 AN x 3/8 Pipe Thread, 6-pk.	\$59.00	\$49.00	\$39.00
C10ANP-90	-10 AN Straight, ea.	\$11.00	\$9.00	\$7.00
	-10 AN Straight, 2-pk.	\$22.00	\$18.00	\$14.00
	-10 AN Straight, 6-pk.	\$59.00	\$49.00	\$39.00
C10ANP-STR	-10 AN Pushlock Hose End, ea.	\$11.00	\$9.00	\$7.00
	-10 AN Pushlock Hose End, 2-pk.	\$22.00	\$18.00	\$14.00
	-10 AN Pushlock Hose End, 6-pk.	\$59.00	\$49.00	\$39.00
-6 AN ALUMINUM FITTINGS				
CP6ANP-30	-6 AN Female to 3/8 Push On 30°, ea.	\$8.00	\$7.00	\$6.00
	-6 AN Female to 3/8 Push On 30°, 2-pk.	\$16.00	\$14.00	\$12.00
	-6 AN Female to 3/8 Push On 30°, 6-pk.	\$45.00	\$35.00	\$30.00
CP6ANP-45	-6 AN Female to 3/8 Push-on 45°, ea.	\$8.00	\$7.00	\$6.00
	-6 AN Female to 3/8 Push-on 45°, 2-pk.	\$16.00	\$14.00	\$12.00
	-6 AN Female to 3/8 Push-on 45°, 6-pk.	\$45.00	\$35.00	\$30.00
CP6ANP-90	-6 AN Female to 3/8 Push On 90°, ea.	\$8.00	\$7.00	\$6.00
	-6 AN Female to 3/8 Push On 90°, 2-pk.	\$16.00	\$15.00	\$12.00
	-6 AN Female to 3/8 Push On 90°, 6-pk.	\$45.00	\$35.00	\$30.00
CP6ANP-120	-6 AN Female to 3/8 Push On 120°, ea.	\$10.00	\$9.00	\$8.00
CP6ANP-180	-6 AN Female to 3/8 Push On 180°, ea.	\$8.00	\$7.00	\$6.00
CP6ANP-S	-6 AN Female to 3/8 Push On Straight, ea.	\$4.00	\$3.00	\$2.00
CP6ANM-Y	-6 AN male Y, ea.	\$10.00	\$9.00	\$8.00

PART #	DESCRIPTION	RETAIL	JOBBER	DEALER
-6 AN STEEL REUSABLE HOSE FITTINGS				
FR500-05X06	-6 AN Straight, ea.	\$11.00	\$9.00	\$7.00
	-6 AN Straight, 2-pk.	\$22.00	\$18.00	\$14.00
	-6 AN Straight, 6-pk.	\$59.00	\$49.00	\$39.00
FR500-05X116	-6 AN Straight 11/16-18 I.F, ea.	\$11.00	\$9.00	\$7.00
	-6 AN Straight 11/16-18 I.F, 2-pk.	\$22.00	\$18.00	\$14.00
	-6 AN Straight 11/16-18 I.F, 6-pk.	\$59.00	\$49.00	\$39.00
FR500-05X58	-6 AN Straight 5/8-18 I.F, ea.	\$11.00	\$9.00	\$7.00
	-6 AN Straight 5/8-18 I.F, 2-pk.	\$22.00	\$18.00	\$14.00
	-6 AN Straight 5/8-18 I.F, 6-pk.	\$59.00	\$49.00	\$39.00
FR545-05X06	-6 AN 45° 9/16-18 Female, ea.	\$11.00	\$9.00	\$7.00
	-6 AN 45° 9/16-18 Female, 2-pk.	\$22.00	\$18.00	\$14.00
	-6 AN 45° 9/16-18 Female, 6-pk.	\$59.00	\$49.00	\$39.00
FR545-05X58	-6 AN 45° 5/8-18 I.F, ea.	\$11.00	\$9.00	\$7.00
	-6 AN 45° 5/8-18 I.F, 2-pk.	\$22.00	\$18.00	\$14.00
	-6 AN 45° 5/8-18 I.F, 6-pk.	\$59.00	\$49.00	\$39.00
FR590-05X06	-6 AN 90° 9/16-18 Female, ea.	\$11.00	\$9.00	\$7.00
	-6 AN 90° 9/16-18 Female, 2-pk.	\$22.00	\$18.00	\$14.00
	-6 AN 90° 9/16-18 Female, 6-pk.	\$59.00	\$49.00	\$39.00
FR590-05X116	-6 AN 90° 11/16-18 I.F, ea.	\$11.00	\$9.00	\$7.00
	-6 AN 90° 11/16-18 I.F, 2-pk.	\$22.00	\$18.00	\$14.00
	-6 AN 90° 11/16-18 I.F, 6-pk.	\$59.00	\$49.00	\$39.00
FR590-05X58	-6 AN 90° 5/8-18 I.F, ea.	\$59.00	\$49.00	\$39.00
	-6 AN 90° 5/8-18 I.F, 2-pk.	\$22.00	\$18.00	\$14.00
	-6 AN 90° 5/8-18 I.F, 6-pk.	\$59.00	\$49.00	\$39.00
-6 AN ALUMINUM STRAIGHT FITTINGS				
C6AN-STR	-6 AN Straight, ea.	\$8.00	\$7.00	\$6.00
	-6 AN Straight, 2-pk.	\$16.00	\$14.00	\$12.00
	-6 AN Straight, 6-pk.	\$43.00	\$37.00	\$31.00
C6AN14-STR	-6 AN Short 9/16-18, ea.	\$8.00	\$7.00	\$6.00
	-6 AN Short 9/16-18, 2-pk.	\$16.00	\$14.00	\$12.00
	-6 AN Short 9/16-18, 6-pk.	\$43.00	\$37.00	\$31.00
C6ANS-STR	-6 AN Long 9/16-18, ea.	\$8.00	\$7.00	\$6.00
	-6 AN Long 9/16-18, 2-pk.	\$16.00	\$14.00	\$12.00
	-6 AN Long 9/16-18, 6-pk.	\$43.00	\$37.00	\$31.00

FiTech Fuel Injection			
Features	Easy Street	GO EFI 2x4	GO EFI 2x4 Power Adder
Horsepower	up to 600 HP	up to 650 HP	up to 1,200 HP
Injectors	4- Flow Matched	8- Flow Matched	8- Flow Matched
Self Learning			
Integrated ECU			
Timing Control	No		
Fan Control	1 Fan	1 Fan	2 Fan
Boost Compatible		No	Yes
Nitrous Control			Yes
Handheld Tuner	Yes	Touchscreen	Touchscreen
Laptop Tuning			Yes

EASY STREET EFI SYSTEM

Pre-programmed with bolt-n-go technology for out of the box performance with minimal input required. Easy tach input, reads tach signal from COIL, HEI, CDI, and many other ignition brands (No timing control). For non boosted engines naturally aspirated applications only.



PART #	DESCRIPTION	RETAIL	JOBBER	DEALER
FI30005	Easy Street EFI	\$795.00	\$755.25	\$715.50

INLINE FUEL FILTER KITS

CPP's Inline Fuel Filter kit is perfect to keep your fuel clean. With a 100 micron rating, these are perfect for catching all contaminants before they enter engine. Features -6AN male ends and are available as a filter only or with push-lock hose connections as a kit. Perfect for fuel injection systems or carbureted systems.



PART #	DESCRIPTION	RETAIL	JOBBER	DEALER
PSFF-K	3/8 Push-on Straight, kit	\$16.00	\$14.00	\$12.00
PSF-AN	Filter, only	\$11.00	\$10.00	\$9.00



#PSF-AN INSTALLED

FiTech Fuel Injection

GO PORT EFI

Imagine if port style EFI was as simple as throttle body style EFI. Having the advantages of easy installation of the throttle body EFI and yet having the precision fuel distribution of port style EFI. FiTech has bridged the gap with the Go Port EFI System.



#FI30254

PART #	DESCRIPTION	RETAIL	JOBBER	DEALER
FI30014	Stand Alone- 200-1200 2.5	\$1,295.00	\$1,230.25	\$1,165.50

BIG BLOCK CHEVROLET

FI30254	Rectangle Port 200-550 HP	\$1,795.00	\$1,705.25	\$1,615.50
FI30258	Rectangle Port 500-1050 HP	\$1,995.00	\$1,895.25	\$1,795.50
FI30454	Oval Port 200-550 HP	\$1,795.00	\$1,705.25	\$1,615.50
FI30458	Oval Port 500-1050 HP	\$1,995.00	\$1,895.25	\$1,795.50

FI32454	351W 200-550 HP MATTE BLACK	\$1,795.00	\$1,705.25	\$1,615.50
FI32458	351W 500-1050 HP MATTE BLACK	\$1,995.00	\$1,895.25	\$1,795.50

SMALL BLOCK FORD

FI32854	SBF 8.2 289-302CID 200-550	\$1,795.00	\$1,705.25	\$1,615.50
FI32858	SBF 8.2 289-302CID 500-105	\$1,995.00	\$1,895.25	\$1,795.50



#FI60011

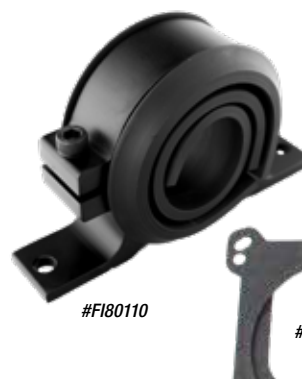

#FI80110



#FI60001

FiTech Fuel Injection

EFI ACCESSORIES

PART #	DESCRIPTION	RETAIL	JOBBER	DEALER
FI40102	340L/H In-Tank Fuel pump	\$110.00	\$104.50	\$99.00
FI44021	Fuel Pressure Regulator, up to 650hp	\$149.00	\$141.55	\$134.10
FI44120	Fuel Pressure Regulator, up to 1,000hp	\$99.00	\$94.05	\$89.10
FI50101	255 L/H Inline Frame Mount EFI	\$95.00	\$90.25	\$85.50
FI60001	4BBL Gasket Kit	\$6.00	\$5.70	\$5.40
FI60011	Throttle Return Spring Kit	\$29.00	\$27.55	\$26.10
FI60012	O ₂ Sensor Bung Kit	\$15.00	\$14.25	\$13.50
FI70050-5	Trans Control Sub harness	\$175.00	\$166.25	\$157.50
FI70063	Throttle Bracket	\$29.95	\$28.45	\$26.95
FI80110	Fuel Pump Mounting Kit	\$22.00	\$20.90	\$19.80

Classic Performance Products, Inc.

LS CONVERSION / HEADERS / EXHAUST MANIFOLDS



INCLUDES CERAMIC-COATED HEADERS!

Long-lasting, ceramic-coated headers provide better heat transfer, increasing performance by improving exhaust flow!

NEW KITS!

APPLICATIONS:

- LS1, LS2, LS3 & LS6 (NOT FOR LS7)

KITS FEATURE*

- Ceramic-Coated Headers
- Transmission Crossmember
- Engine Side Mount Adapters
- Transmission Pad
- Fit Rite™ Engine Mount Adapters
- Oil Pan Kit with Sump Baffle & Oil Pick Up Tube*
- All Mounting Hardware



#7387LS1-FRK

LS INSTALL KITS

CPP provides everything you need to install a modern, dependable, light-weight, low maintenance, high powered V8. Works with all Vortec and most LS engines.

PART #	DESCRIPTION	RETAIL	JOBBER	DEALER	PART #	DESCRIPTION	RETAIL	JOBBER	DEALER
7387LS1-FRK	1973-87 Chevy Truck, kit	\$899.00	\$825.00	\$729.00	6467LS1-FRK	1964-67 Chevelle, kit	\$1,249.00	\$1,149.00	\$1,034.00
5557LS1-FRK	1955-57 Chevy Fullsize, Tri-Five, kit	\$1,249.00	\$1,149.00	\$1,034.00	6872LS1-FRK	1968-72 Chevelle, kit	\$1,299.00	\$1,149.00	\$1,034.00
6774LS1-FRK	1967-69 Camaro, 1968-74 Nova, kit	\$1,199.00	\$1,149.00	\$999.00	7887LS1-FRK	1978-87 G Body, kit	\$1,399.00	\$1,195.00	\$1,075.00
7081LS1-FRK	1970-81 Camaro, kit	\$1,199.00	\$1,149.00	\$999.00					

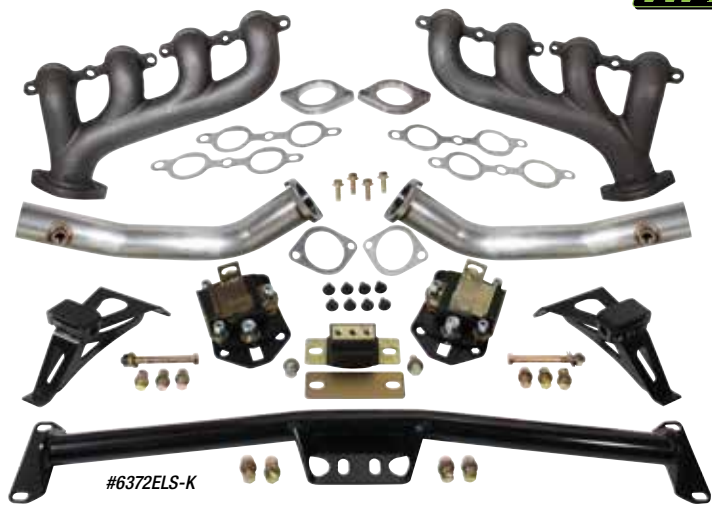

#6372ELS-K



#7081ELS-K

LS ECONOMY INSTALL KITS

CPP also offers an economical alternative to install your LS/Vortec engine.

PART #	DESCRIPTION	RETAIL	JOBBER	DEALER
6372ELS-K	1963-72 Chevy Truck, kit	\$599.00	\$539.00	\$449.00
7387ELS-K	1973-87 Chevy Truck, kit	\$599.00	\$539.00	\$449.00
5557ELS-K	1955-57 Chevy Fullsize, Tri-Five, kit	\$799.00	\$719.00	\$599.00
5964ELS-K	1959-64 Chevy Car, kit	\$799.00	\$719.00	\$599.00
6570ELS-K	1965-70 Chevy Car, kit	\$799.00	\$719.00	\$599.00
7081ELS-K	1970-81 Camaro, kit	\$899.00	\$791.00	\$674.00
6467ELS-K	1964-67 Chevelle, kit	\$899.00	\$791.00	\$674.00
6872ELS-K	1968-72 Chevelle, kit	\$899.00	\$791.00	\$674.00
7887ELS-K	1978-87 G Body, kit	\$699.00	\$615.00	\$524.00

APPLICATIONS:

- LS1, LS2, LS3, LS6 & Vortec (NOT FOR LS7)

ECONOMY KITS FEATURE*

- Exhaust Manifolds
- Head Pipe Adapters
- Engine Side Mount Adapters
- Transmission Crossmember
- Transmission Pad
- Fit Rite™ Engine Mount Adapters
- Oil Pan with Sump Baffle & Oil Pick Up Tube*
- All Mounting Hardware

NEW KITS!

HEAD PIPES INCLUDED!

CPP's head pipe adapters are designed to perfectly fit the gap between our LS exhaust manifold and your exhaust system, with maximum clearance in mind!

Note: Will only work with CPP's LS Exhaust Manifolds.

Notes: *Chevy truck applications do not include the oil pan, windage tray or oil pick up tube. Camaro applications do not include engine side mount adapters. May not work with LSX heads, and dry sump oil systems. Kits will not work for LS7 engines. Kit contents and prices may vary between certain applications.



HEADERS FOR LS ENGINES

For use with all LS Series engines (except LS7) and popular 4.8-6.0 Vortec engines. Comes in beautiful silver ceramic coating. These full length and 3/4 length header kits come complete with gaskets, hardware and collectors and provides better clearance when using with CPP's 400 and 500 Series™ power steering boxes.

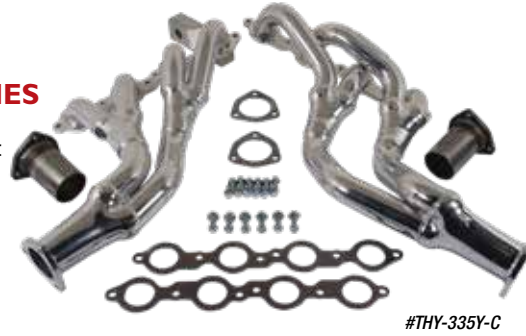

PART #	DESCRIPTION	RETAIL	JOBBER	DEALER
THY-358-C	1955-57 Chevy Fullsize, full length	\$639.00	\$607.00	\$576.00
D3347	1962-67 Nova, 3/4 length	\$580.00	\$551.00	\$522.00
THY-335Y-C	1962-67 Nova with aftermarket front clip, Mustang II Style front steering only, full length	\$679.00	\$620.00	\$560.00

PART #	DESCRIPTION	RETAIL	JOBBER	DEALER
THY-320-C	1967-69 Camaro, 1968-74 Nova, 1-3/4" to 1-7/8" 4:1 stepped header	\$659.00	\$626.00	\$593.00
D335	1970-81 Camaro, 3/4 length	\$657.00	\$624.00	\$591.00
THY-346-C	1964-67 Chevelle, 3/4 length	\$569.00	\$519.00	\$469.00
D3336	1964-67 Chevelle, 3/4 length	\$679.00	\$625.00	\$571.00



COMPLETE LS EXHAUST MANIFOLD KIT WITH HEAD PIPE ADAPTERS

Tight-to-the-block design makes these manifolds the perfect fit and it's contoured shape provides excellent performance! CPP's own head pipe adapters are designed to perfectly fill the gap between our LS exhaust manifold and your exhaust system, with maximum clearance in mind. Includes gaskets and mating flanges. CPP's head pipe adapters are designed to perfectly fill the gap between our LS exhaust manifold and your exhaust system, with maximum clearance in mind. Gaskets and flanges are included. These are designed to perfectly fit the gap between our LS exhaust manifold and your exhaust system, with maximum clearance in mind.



PART #	DESCRIPTION	RETAIL	JOBBER	DEALER
FOR 1963-87 CHEVY TRUCK, 1955-70 CHEVY FULLSIZE				
CPLSMK-R	raw, kit	\$294.00	\$265.00	\$224.00
CPLSMK-B	black, kit	\$319.00	\$287.00	\$243.00
CPLSMK-C	chrome, kit	\$459.00	\$413.00	\$348.00
CPLSMK-SC	silver ceramic, kit	\$418.00	\$376.00	\$317.00
CPLSMK-BCA	black ceramic, kit	\$479.00	\$431.00	\$363.00

PART #	DESCRIPTION	RETAIL	JOBBER	DEALER
FOR 1964-72 CHEVELLE				
6472MK-R	raw, kit	\$294.00	\$265.00	\$224.00
6472MK-B	black, kit	\$319.00	\$287.00	\$243.00
6472MK-C	chrome, kit	\$459.00	\$413.00	\$348.00
6472MK-SC	silver ceramic, kit	\$418.00	\$376.00	\$317.00
6472MK-BCA	black ceramic, kit	\$479.00	\$431.00	\$363.00

CAST IRON LS EXHAUST MANIFOLDS

WILL FIT APPLICATIONS WITH LS CONVERSION:
*NOT FOR LS7

- 1963-87 Chevy Truck,
- 1955-70 Fullsize
- 1970-81 Camaro
- 1964-72 Chevelle
- 1978-87 G-Body
- 1962-67 Nova (IFS only, headpipe adapter will only work with CPP's exhaust manifolds)

PART #	PART #	PART #	PART #	PART #
CPLSMK-R	raw with head pipe adapter, kit	\$289.00	\$254.00	\$229.00
CPLS-EHR	raw, pair	\$225.00	\$203.00	\$169.00
CPLS-EHB	black, pair	\$250.00	\$225.00	\$188.00
CPLS-EHC	chrome, pair	\$390.00	\$351.00	\$293.00
CPLS-EHSCA	silver ceramic, pair	\$349.00	\$314.00	\$262.00
CPLS-EHBCA	black ceramic, pair	\$410.00	\$369.00	\$308.00

HEAD PIPE ADAPTERS ONLY

PART #	DESCRIPTION	RETAIL	JOBBER	DEALER
CPP-LSHAP	1963-87 Chevy Truck, 1955-70 Fullsize, pr.	\$69.00	\$62.00	\$55.00
6472LS-HP	1964-72 Chevelle, pr.	\$69.00	\$62.00	\$55.00
7081LSHAP	1970-81 Camaro, pr.	\$69.00	\$62.00	\$55.00

Note: Head pipe adapter will only work with CPP's Exhaust Manifolds. 1962-67 Nova must have front-end IFS kit.

LS EXHAUST MANIFOLD FLANGES

PART #	DESCRIPTION	RETAIL	JOBBER	DEALER
CPP-LSF	Flanges	\$10.00	\$10.00	\$6.00
CPP-LSFG	Gasket	\$5.00	\$5.00	\$2.00

EXCLUSIVE DESIGN

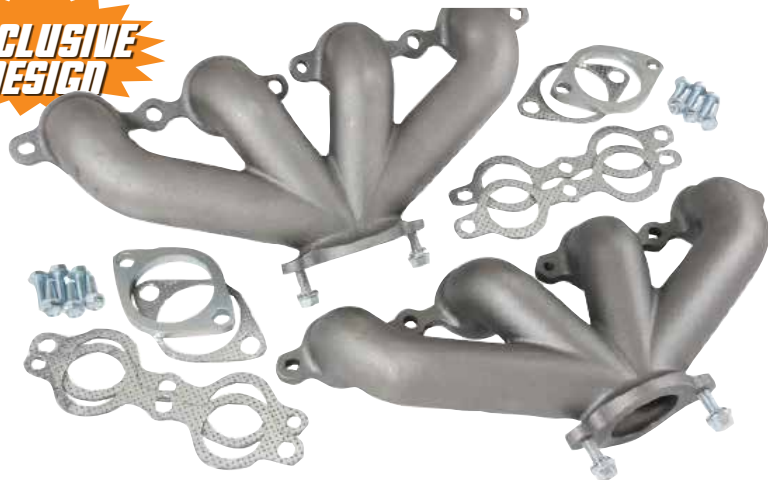

SHOWN INSTALLED ON 1967 CAMARO WITH LS SWAP & 500 SERIES™ POWER STEERING BOX

CENTER DUMP CAST IRON LS EXHAUST MANIFOLDS

New LS Cast exhaust manifolds are now available, designed for rear steer applications such as the 1967-69 Camaro, 1968-74 Nova and other GM LS powered applications. These manifolds are designed with a center dump configuration. Unlike most stock style manifolds, this center dump configuration provides more space at the rear of the motor and firewall where extra space is often just not available. The smooth round ports allow for better flow and increased horsepower. Includes gaskets, head pipe flanges and all hardware. Available for all popular LS applications except LS7 and LS9.

AVAILABLE IN 4 FINISHES!



PART #	DESCRIPTION	RETAIL	JOBBER	DEALER
LSCDM-R	raw, kit	\$225.00	\$203.00	\$169.00
LSCDM-C	chrome, kit	\$390.00	\$351.00	\$293.00
LSCDM-B	black, kit	\$330.00	\$300.00	\$225.00
LSCDM-SC	silver ceramic, kit	\$349.00	\$314.00	\$262.00



HEAD PIPE ADAPTERS



OLD STYLE LS CAST IRON MANIFOLD PORT

PERFORMANCE LS CAST IRON MANIFOLD LARGE PORT

EXCLUSIVE DESIGN



REAR DUMP CAST IRON LS EXHAUST MANIFOLDS

Our brand new Performance Exhaust Cast Iron Manifolds were designed with small engine compartments in mind. These slick-looking matched manifolds bolt on cleanly, providing plenty of space for plugs and plug wires. Features larger ports than old style manifolds for better flow and increased horsepower. Rear dump configuration makes any size exhaust system an easy installation.

AVAILABLE IN 4 FINISHES!



PART #	DESCRIPTION	RETAIL	JOBBER	DEALER
LSRDM-R	raw, kit	\$225.00	\$203.00	\$169.00
LSRDM-C	chrome, kit	\$390.00	\$351.00	\$293.00
LSRDM-B	black, kit	\$330.00	\$300.00	\$225.00
LSRDM-SC	silver ceramic, kit	\$349.00	\$314.00	\$262.00



LS & LT ENGINE RETRO-FIT OIL PANS

CPP now offers the newest LT oil pan, along with the LS for your engine swap. Specifically designed for maximum ground clearance as well as overall fitment into your application. Available in natural Cast aluminum or black. Does not include dipstick or sump baffle. Hardware included.

PART #	DESCRIPTION	RETAIL	JOBBER	DEALER
302-1BK	LS Retro-Fit Oil Pan, Black	\$440.00	\$418.45	\$396.00
302-2BK	LS Retro-Fit Oil Pan, Black (additional front clearance)	\$423.00	\$402.00	\$381.00
302-3	LS Retro-Fit Oil Pan (additional front clearance)	\$359.00	\$341.00	\$323.00
302-20	Gen V LT Retro-Fit Oil Pan, Aluminum	\$400.00	\$380.00	\$360.00
302-20BK	Gen V LT Retro-Fit Oil Pan, Black	\$410.00	\$389.50	\$369.00

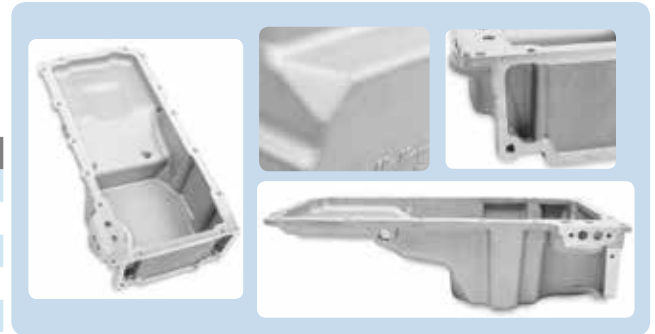

RAW STEEL SOLID
#BWG13-LS3



LS FUEL RAIL COVERS

Designed to fit most LS Engines (LS1, LS2, LS3, LS and LS92), these are perfect upgrade to the valve covers and to dress up the stock rails while hiding the wiring harness and injectors. Each kit includes left and right covers, stainless button head and mounting adapters. Available in raw paintable steel or polished chrome finish.

PART #	DESCRIPTION	RETAIL	JOBBER	DEALER
LSFRC-1PE	LS fuel rail covers, raw steel, slotted, kit	\$95.00	\$90.00	\$86.00
LSFRC-1PS	LS fuel rail covers, polished, slotted, kit	\$125.00	\$119.00	\$112.00
BWG13-LS3	LS fuel rail covers, raw steel, solid, kit	\$300.00	\$285.00	\$270.00



OUT WITH THE OLD!...IN WITH THE NEW!



LS ENGINE PEDESTALS AND MOUNTS

Our fabricated direct replacement pedestals are made specifically with the LS install in mind. Direct, bolt-on, replacement for each specific application.

PART #	DESCRIPTION	RETAIL	JOBBER	DEALER
LSCSM-KR	Clam Shell mount & LS side adapter mount (rubber), kit	\$189.00	\$169.00	\$149.00
LSCSM-KP	Clam Shell mount & LS side adapter mount (POLYPLUS), kit	\$209.00	\$189.00	\$159.00
90294M	Clam Shell replacement mount, kit	\$89.00	\$80.00	\$63.00
6467MP-LS	1964-67 Chevelle, kit	\$89.00	\$80.00	\$63.00
6872MP-LS	1968-72 Chevelle, kit	\$89.00	\$80.00	\$63.00

Note: #90294M Clam Shell Mount Kit only works with CPP's Fit Rite™ LS Mounts.

Classic Performance Products, Inc.

LS CONVERSION / LS COMPONENTS



#CMW-LSC-01-M

LS VALVE COVER ACCESSORIES

PART #	DESCRIPTION	Retail	jobber	dealer
CMW-CRK-LS	Coil Relocation Kit	\$175.00	\$166.35	\$157.59
CMW-LSC-01-B	Coil Covers-Black (w/Oil Fill Cutout on Pass Side)	\$215.00	\$204.51	\$193.74
CMW-LSC-01-M	Coil Covers-Mill Finish (w/Oil Fill Cutout on Pass Side)	\$212.00	\$201.57	\$190.96
CMW-LSC-02-B	Coil Covers-Black (w/o Oil Fill Cutout)	\$215.00	\$204.51	\$193.74
CMW-LSC-02-M	Coil Covers-Mill Finish (w/o Oil Fill Cutout)	\$196.00	\$185.92	\$176.13
CMW-LSV-01	Valve Covers (Billet)	\$1,339.00	\$1,272.05	\$1,205.10



#CPLSRRACM



#CPLSRRM INSTALLED

LS ENGINE REMOTE RESERVOIR KITS

CPP's LS Engine Remote Power Steering Reservoir Kit has everything you need to install a remote reservoir to your LS Engine. These kits include a mounting bracket along with the Corvette remote reservoir and cap. Our #CPLSRRACM comes with provisions to support an air intake tube and filter. Both mounting kits will only work with aftermarket accessory drives, not stock.

PART #	DESCRIPTION	RETAIL	JOBBER	DEALER
CPLSRRM	Remote Reservoir Mounting Kit, kit	\$99.00	\$89.00	\$75.00
CPLSRRACM	Remote Reservoir Mounting Kit for 90° air filter, kit	\$99.00	\$89.00	\$75.00

REMOTE RESERVOIR TYPE II CORVETTE MOUNTING BRACKETS

CPP now offers simple but very effective ways to mount your type II power steering reservoir. Our brand new steel, black zinc-coated brackets are available to take the guess work out of mounting these tanks. If you have a tight-fit straight mounting point, our flat version will mount on just about any flat, vertical surface like a core support, inner panel, etc. If you need room to adjust, the long bracket will allow for custom bending to get the fit and mounting point just right.



PART #	DESCRIPTION	RETAIL	JOBBER	DEALER
CP11625	flat surface, kit	\$99.00	\$89.00	\$75.00
CP11629	bend to fit, kit	\$99.00	\$89.00	\$75.00

View the full install of this kit & more CPP items on the PROJECT '55 REVIVE!

SCAN QR CODE:

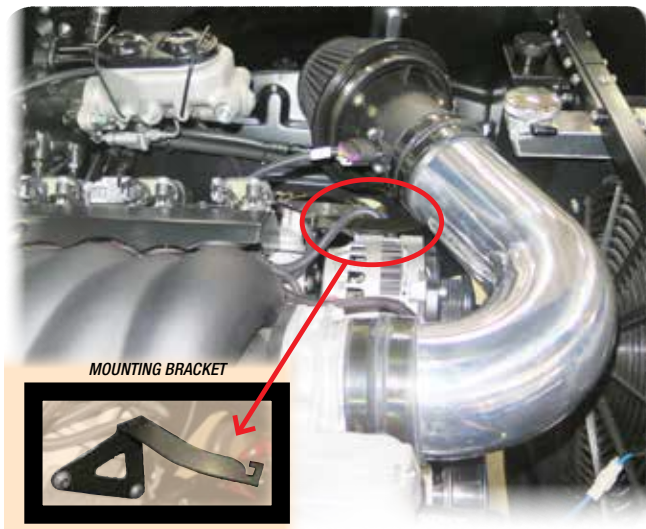

MOUNTING BRACKET



#90ANF-4

LS AIR INTAKE KITS

The Universal LS Air Intake Kit is a complete do-it-yourself custom cone filter intake kit. It includes the necessary tubing, clamps, and cone-style filter for your LS conversion. The 120-degree tube positions the filter closer to the engine and farther from the radiator, while the 90-degree kit positions the filter a little closer to the radiator. It works great with the Eddie Motorsports S Drive and we offer an optional bracket for use with a remote power steering reservoir/filter that supports the assembly. Both the 120° and 90° kits include a universal filter mounting bracket. The bracket attaches to the front of the cylinder head. The 6" filter kit has a built in MAF sensor mount while the 4" filter kit includes a weld on MAF sensor mount. Filters are washable and the tubes are polished aluminum.

PART #	DESCRIPTION	RETAIL	JOBBER	DEALER
COMPLETE KITS				
90ANF-4	4" filter, reducer MAF with 90° tube, kit	\$249.00	\$224.00	\$189.00
90ANF-6	6" filter, reducer MAF with 90° tube, kit	\$249.00	\$224.00	\$189.00
120ANF-4	4" filter, MAF mount with 120° tube, kit	\$249.00	\$224.00	\$189.00
120ANF-6	6" filter, MAF mount with 120° tube, kit	\$249.00	\$224.00	\$189.00
MOUNTING BRACKET				
11624K	90°, kit	\$19.00	\$17.00	\$14.00
11577K	90° (for Corvette-style remote reservoir), kit	\$19.00	\$17.00	\$14.00
11621K	120°, kit	\$19.00	\$17.00	\$14.00



BY LOKAR INC.

MUSCLE CAR PEDAL ASSEMBLIES

These pedal assemblies are manufactured from lightweight aluminum. Also available for "Drive By Wire" applications. Includes all hardware needed for installation.



#CMW-MCP-A1-M-DBW

BILLET THROTTLE ASSEMBLIES PEDAL COVE

These black anodized assemblies are fully a feature machined high molded rubber inser They are sold as a complete kit, including the spring loaded gas pedal tha does not require drilling for installation.



BY LOKAR INC.

PART #	DESCRIPTION	RETAIL	JOBBER	DEALER
CMW-EB-P1-G	E-Brake Cover (Gray)	\$53.00	\$49.90	\$47.28
AUTOMATIC				
CMW-MCP-A1-A	1967-69 Camaro, 1964-66 A Body, 1968-74 Nova	\$542.00	\$514.69	\$487.60
CMW-MCP-A2-A	1967 A-Body	\$542.00	\$514.69	\$487.60
CMW-MCP-A3-A	1968-72 Chevelle	\$542.00	\$514.69	\$487.60
MANUAL				
CMW-MCP-A1-M	1967-69 Camaro, 1964-66 A Body, 1968-74 Nova	\$717.00	\$681.04	\$645.19
CMW-MCP-A2-M	1967 A-Body	\$717.00	\$681.04	\$645.19
CMW-MCP-A3-M	1968-72 Chevelle	\$717.00	\$681.04	\$645.19
THROTTLE ASSEMBLY				
CMW-MCP-P1	Mechanical, 1964-67 Chevelle/1967-69 Camaro/1968-74 Nova	\$202.00	\$191.79	\$181.69
CMW-MCP-P2	Mechanical 2nd Gen Camaro / Universal	\$202.00	\$191.79	\$181.69
CMW-MCP-P3	Mechanical 1968-72 Chevelle	\$202.00	\$191.79	\$181.69
CMW-MCP-P4	Drive By Wire	\$82.00	\$78.28	\$74.16

PART #	DESCRIPTION	RETAIL	JOBBER	DEALER
CMW-TA-206-B1	1967-69 Camaro, 1964-67 GM A-Body, 1968-74 Nova	\$206.00	\$195.70	\$185.40
CMW-TA-206-B2	Second Generation Camaro, Universal Firewall Mount	\$206.00	\$195.70	\$185.40
CMW-TA-206-B3	1968-72 GM A-Body	\$206.00	\$195.70	\$185.40
CMW-TA-206-BKA1	With Matching Pedal Cover (Automatic Transmission) 1967-69 Camaro, 1964-67 GM A-Body, 1968-74 Nova	\$309.00	\$293.55	\$278.10
CMW-TA-206-BKA2	With Matching Pedal Cover (Automatic Transmission) Second Generation Camaro, Universal Firewall Mount	\$309.00	\$293.55	\$278.10
CMW-TA-206-BKA3	With Matching Pedal Cover (Automatic Transmission) 1968-72 GM A-Body	\$309.00	\$293.55	\$278.10
CMW-TA-206-BKM1	With Matching Pedal Covers (Manual Transmission) 1967-69 Camaro, 1964-67 GM A-Body, 1968-74 Nova	\$351.00	\$341.50	\$323.52
CMW-TA-206-BKM2	With Matching Pedal Covers (Manual Transmission) Second Generation Camaro, Universal Firewall Mount	\$361.00	\$342.48	\$324.45
CMW-TA-206-BKM3	With Matching Pedal Covers (Manual Transmission) 68-72 GM A-Body	\$361.00	\$342.48	\$324.45
CMW-TA-206-DBW	Black Anodized Throttle Assembly (Drive By Wire Setup)	\$68.00	\$64.58	\$61.18

BILLET PEDAL COVERS

These black anodized billet pedal pad covers are uniquely designed with rubber inserts for either manual or automatic applications. Sold individually and do not require drilling for installation.

PART #	DESCRIPTION	RETAIL	JOBBER	DEALER
CMW-BPA-206-B	Automatic Brake Pad-Blk	\$101.00	\$95.89	\$90.85
CMW-BPM-206-B	Manual Clutch/Brake Pad-Blk	\$88.00	\$83.17	\$78.80
CMW-EB-P1-B	E-Brake Cover (Black)	\$53.00	\$49.90	\$47.28



#CMW-BPM-206-B

#CMW-EB-P1-B

DRIVE BY WIRE THROTTLE PEDAL BRACKETS

You will no longer need to try and figure out a proper way to mount your gas pedal when converting your car to late model "Drive by Wire" LS Engine conversions. Late model LS Series (2003-up) have an electronic actuated throttle body verses older traditional cable actuated assemblies. All kits include a Corvette electric throttle pedal. This pedal is a direct interchange to the plastic CTS pedal included in GM crate engines. It looks the most like an original GM pedal used from the 1950's thru the 1980's. These conversion kits are year and model specific giving you a platform to neatly mount the included GM throttle pedal.

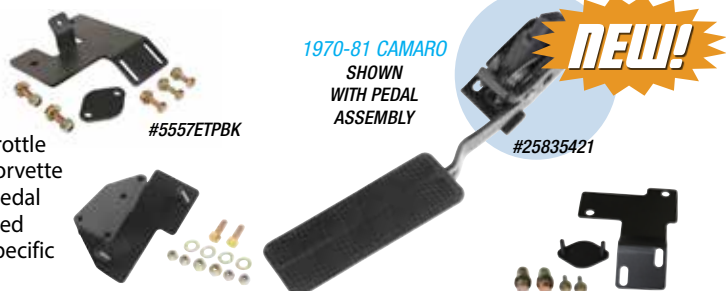

#5557ETPBK

1970-81 CAMARO SHOWN WITH PEDAL ASSEMBLY



#25835421

#7081ETPBK

#6467ETPBK

PART #	DESCRIPTION	RETAIL	JOBBER	DEALER
5559ETPBK	1955-59 Chevy Truck	\$139.00	\$125.00	\$111.00
6370ETPBK	1963-70 Chevy Truck	\$139.00	\$125.00	\$111.00
7172ETPBK	1971-72 Chevy Truck	\$139.00	\$125.00	\$111.00
5557ETPBK	1955-57 Chevy Fullsize, Tri-Five	\$139.00	\$125.00	\$111.00
5864ETPBK	1958-64 Chevy Fullsize	\$139.00	\$125.00	\$111.00
6267ETPBK	1962-67 Nova	\$139.00	\$125.00	\$111.00

PART #	DESCRIPTION	RETAIL	JOBBER	DEALER
6874ETPBK	1968-74 Nova	\$139.00	\$125.00	\$111.00
6769ETPBK	1967-69 Camaro	\$139.00	\$125.00	\$111.00
7081ETPBK	1970-81 Camaro	\$139.00	\$125.00	\$111.00
6467ETPBK	1964-67 Chevelle	\$139.00	\$125.00	\$111.00
25835421	GM Pedal Assembly	\$95.00	\$91.00	\$85.00

Classic Performance Products, Inc.

POPULAR UPGRADES / CROSSMEMBERS / ACCESSORIES

AS SEEN ON
**CPP's
Comeback Camaro**



SCAN QR CODE:



BY LOKAR INC.

SHIFTER ARMS

These shifter arms are machined from billet aluminum and available with a machined, or black or gray powdercoated finish. Available in 8" length with a 30-degree kickback or 10", fixed kickback or adjustable. They fit Hurst, Tremec TK0-500, TK0-600 and T56 with the standard 2-bolt flange. Shift knob sold separately, 3/8"-16 threaded stud.



PART #	DESCRIPTION	RETAIL	JOBBER	DEALER
CMW-SH-202-10	10" Gray Powder Coated Truss	\$134.00	\$127.21	\$120.51
CMW-SH-202-8	8" Gray Powder Coated Truss	\$129.00	\$122.31	\$115.88
CMW-SH-205-10	10" Black Anodized Truss	\$113.00	\$107.64	\$101.97
CMW-SH-205-8	8" Black Anodized Truss	\$111.00	\$105.68	\$100.72
CMW-SH-203-10	10" Black Anodized w/Mesh Insert	\$169.00	\$160.47	\$152.03
CMW-SH-203-8	8" Black Anodized w/Mesh Insert	\$144.00	\$136.99	\$129.78
CMW-SH-204-10	10" Adjustable Billet	\$221.00	\$210.38	\$199.31



DOOR & WINDOW HANDLES

PART #	DESCRIPTION	RETAIL	JOBBER	DEALER
CHROME				
CMW-PT-102-EF	Door Handles, pre-1948 Ford	\$93.00	\$88.07	\$83.43
CMW-PT-102	Door Handles	\$99.00	\$93.94	\$88.99
CMW-PT-104-EF	Vent Window Cranks, pre-1948 Ford	\$93.00	\$88.07	\$83.43
CMW-PT-104	Vent Window Cranks	\$99.00	\$93.94	\$88.99
CMW-PT-103-EF	Window Cranks, pre-1948 Ford	\$93.00	\$88.07	\$83.43
CMW-PT-103	Window Cranks	\$99.00	\$93.94	\$88.99
BLACK ANODIZED W/MACHINED HIGHLIGHTS & MESH INSERTS				
CMW-PT-302	Door Handles	\$108.00	\$102.74	\$97.34
CMW-PT-304	Vent Window Cranks	\$99.00	\$93.94	\$88.99
CMW-PT-303	Window Cranks	\$111.00	\$105.68	\$100.12
BLACK POWDERCOATED W/MACHINED HIGHLIGHTS				
CMW-PT-402	Door Handles (Truss style)	\$111.00	\$105.68	\$100.12
CMW-PT-403	Window Cranks (Truss style)	\$108.00	\$102.74	\$97.34
CMW-PT-404	Vent Window Cranks (Truss style)	\$99.00	\$93.94	\$88.99
GRAY POWDER COAT WITH MACHINED HIGHLIGHTS				
CMW-PT-202	Door Handles	\$124.00	\$117.42	\$111.24
CMW-PT-204	Vent Window Cranks	\$113.00	\$107.64	\$101.97
CMW-PT-203	Window Cranks	\$129.00	\$122.31	\$115.88



#CP90295

FIT Rite™

ADJUSTABLE TRANSMISSION CROSSMEMBERS

CPP Fit Rite™ adjustable crossmembers take the guessing out of finding the right fit. These are designed to give the most amount of adjustability when installing your LS engine and 700R4 or 4L60 style transmissions. These work great when used with our LS install kit or CPP's Fit Rite™ Adjustable engine brackets.

PART #	DESCRIPTION	RETAIL	JOBBER	DEALER
CP90233	1967-69 Camaro, 4L75	\$175.00	\$149.00	\$119.00
CP90232	1967-69 Camaro, 700R4	\$175.00	\$149.00	\$119.00
CP90337	1967-69 Camaro, 4L60	\$175.00	\$149.00	\$119.00
CP90311	1970-81 Camaro, 4L60E	\$175.00	\$149.00	\$119.00
CP90312	1970-81 Camaro, 4L75	\$175.00	\$149.00	\$119.00



#CP90312

CHEVELLE CROSSMEMBERS SHOWN WITH PARKING BRAKE CABLE BRACKETS



#CP90304

PART #	DESCRIPTION	RETAIL	JOBBER	DEALER
CP90295	1964-72 Chevelle, 4L60 (open frame)	\$175.00	\$149.00	\$119.00
CP90304	1964-67 Chevelle, 4L60 (closed frame)	\$175.00	\$149.00	\$119.00
CP90305	1968-72 Chevelle, closed frame	\$175.00	\$149.00	\$119.00
6472ATCM-K	1964-72 Chevelle, E-Brake Cable Bracket, kit	\$29.00	\$25.00	\$19.00

Notes: The parking brake cable will not re-attach to the transmission crossmembers on 1964-72 Chevelle. The adjustable cable bracket is needed to re-connect the parking brake cable. Use part #6472ATCM-K.

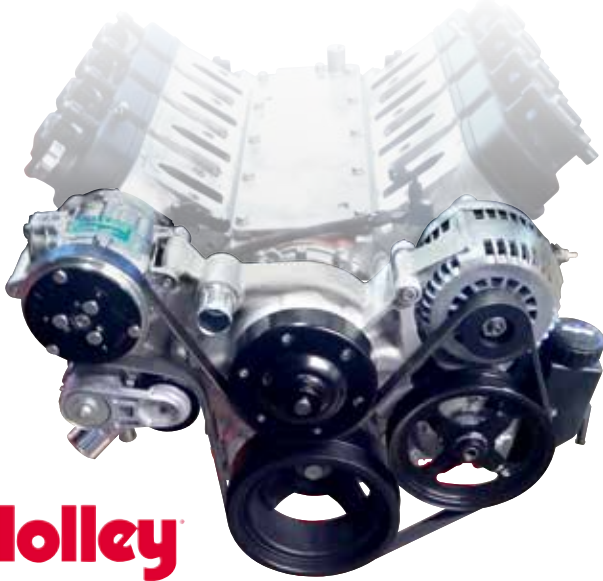

Holley

COMPLETE ACCESSORY DRIVE SYSTEMS - HIGH MOUNT

The most cost effective LS/LT bracket solution on the market! Holley's High-Mount system comes with everything you need including: A/C compressor, Alternator, P/S pump, idler pulley and tensioner assembly. All pulleys and the belt are supplied as well as universal brackets that fit virtually all common LS engines regardless of water pump and harmonic balancer offsets further reducing cost and complexity compared to competitive products. Easy assembly was a priority during the entire development of this accessory solution. These simple, dedicated installation kits allow easy fitment to Corvette, F-Body or Truck drive offsets OEM quality natural finish die castings for clean looks and durability. Can be polished, coated, painted or plated.

PART #	DESCRIPTION	RETAIL	JOBBER	DEALER
20-136	R4 AC Compressor, natural	\$1,327.00	\$1,261.00	\$1,194.00
20-137	SD508 AC Compressor, natural	\$1,327.00	\$1,261.00	\$1,194.00
20-138	SD7 Sanden AC Compressor, natural	\$1,327.00	\$1,261.00	\$1,194.00

COMPLETE ACCESSORY DRIVE SYSTEMS - MID MOUNT

Holley's Mid-Mount complete accessory system has all accessories pulled in tighter than other accessory drives. At the heart of the system is a "bracketless" design (Patent Pending), where the accessories bolt directly to the water pump for a clean, integrated form. The design offers superb engine visibility to show off your horsepower, not your accessories. Among the many swap friendly features are bottom heater outlets for clearance in tight applications. The Holley designed alternator is just as innovative. This premium alternator utilizes hairpin/square wire, 6-phase technology as found on the C7 Corvette. The water pump also shares its design efficiencies with that of the C7 Corvette. The compact and reliable SD7 A/C compressor and Type II P/S pump with baffled reservoir are also integrated. The Mid-Mount drive completes Holley's trilogy of accessory solutions giving a third option compared to the High and Low-Mount previously released. All three accessory solutions are for LS engines. When we say "complete", we mean complete. The Mid-Mount system comes with everything you need. All accessories are included; the water pump, A/C compressor, Alternator, P/S pump with reservoir, and the crank damper. All pulleys and the belt are supplied. Even heater hose adapters, power steering to -6 AN hardline, and the alternator plug/harness are included. Easy assembly was a priority during the entire development of this accessory solution. Color graphical instructions walk you through every step of the ultra-easy installation.

PART #	DESCRIPTION	RETAIL	JOBBER	DEALER
20-180	SD7 AC Compressor, natural	\$2,400.00	\$2,280.00	\$2,280.00
20-180BK	SD7 AC Compressor, black	\$2,500.00	\$2,375.00	\$2,375.00
20-180P	SD7 AC Compressor, polished	\$2,800.00	\$2,660.00	\$2,660.00

PART #	DESCRIPTION	RETAIL	JOBBER	DEALER
20-185	SD7 AC Compressor, natural	\$1,800.00	\$710.00	\$1,710.00
20-185BK	SD7 AC Compressor, black	\$1,900.00	\$1,805.00	\$1,805.00
20-185P	SD7 AC Compressor, polished	\$2,200.00	\$2,090.00	\$2,090.00

Connect with us!



@CLASSICPERFORM

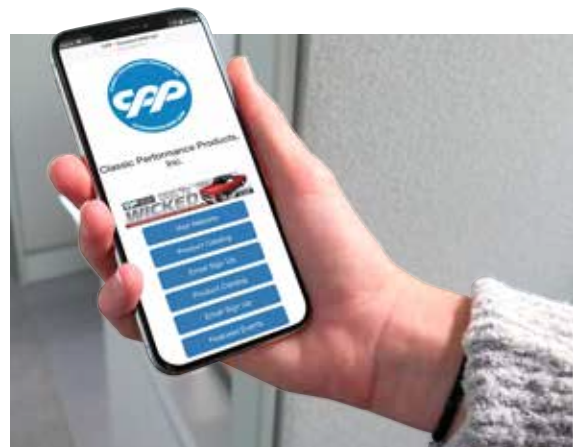

Classic Performance Products, Inc.

POPULAR UPGRADES / ENGINE SERPENTINE PULLEY KITS

RAVEN SERPENTINE PULLEY KIT

Eddie Motorsports' S-Drive serpentine pulley kits include everything to accessorize your engine. Kits come complete with all of the necessary precision CNC machined billet aluminum brackets & pulleys, which are made in the USA, as well as high quality, name brand components; Tuff Stuff aluminum water pump, Sanden compact AC compressor, Maval power steering pump with attached plastic reservoir, Powermaster 170 amp alternator. High performance 8 rib kits handle 33% more torque and horsepower than standard 6 rib systems. Available in three black finishes and with natural or ALL BLACK finished components. Specify steering type in the order notes when placing your order (power steering gearbox or rack and pinion). Also available for 8-rib.

FOR CHEVY SMALL BLOCK

PART #	DESCRIPTION	RETAIL	JOBBER	DEALER
CHEVY SMALL BLOCK				
MS118-55	Plastic or Remote Reservoir, Gloss or matte black	\$2,250.00	\$2,025.00	\$1,913
MS118-55	Plastic or Remote Reservoir, Black Anodized	\$2,330.00	\$2,097.00	\$1,981.00
MS118-55	Billet Aluminum Reservoir, Gloss or matte black	\$2,445.00	\$2,200.00	\$2,078.0
MS118-55	Billet Aluminum Reservoir, Black Anodized	\$2,545.00	\$2,291.00	\$2,163.00
CHEVY SMALL BLOCK, NO A/C				
MS118-57	Plastic or Remote Reservoir, Gloss or matte black	\$2,075.00	\$1,868.00	\$1,764.00
MS118-57	Plastic or Remote Reservoir, Black Anodized	\$2,155.00	\$1,940.00	\$1,832.00
MS118-57	Billet Aluminum Reservoir, Gloss or matte black	\$2,270.00	\$2,043.00	\$1,930.00
MS118-57	Billet Aluminum Reservoir, Black Anodized	\$2,370.00	\$2,133.00	\$2,015.00

FOR CHEVY BIG BLOCK

PART #	DESCRIPTION	RETAIL	JOBBER	DEALER
CHEVY BIG BLOCK				
MS118-50	Plastic or Remote Reservoir, Gloss or matte black	\$2,320.00	\$2,088.00	\$1,972.00
MS118-50	Plastic or Remote Reservoir, Black Anodized	\$2,400.00	\$2,160.00	\$2,040.00
MS118-50	Billet Aluminum Reservoir, Gloss or matte black	\$2,515.00	\$2,264.00	\$2,138.00
MS118-50	Billet Aluminum Reservoir, Black Anodized	\$2,615.00	\$2,354.00	\$2,223.00
CHEVY BIG BLOCK, NO A/C				
MS118-52	Plastic or Remote Reservoir, Gloss or matte black	\$2,145.00	\$1,931.00	\$1,823.00
MS118-52	Plastic or Remote Reservoir, Black Anodized	\$2,225.00	\$2,003.00	\$1,891.00
MS118-52	Billet Aluminum Reservoir, Gloss or matte black	\$2,340.00	\$2,106.00	\$1,989.00
MS118-52	Billet Aluminum Reservoir, Black Anodized	\$2,440.00	\$2,196.00	\$2,074.00

FOR LS CHEVY WITH VARIABLE VALVE TIMING

PART #	DESCRIPTION	RETAIL	JOBBER	DEALER
LS CHEVY VVT				
MS118-80	Plastic or Remote Reservoir, Gloss or matte black	\$2,745.00	\$2,471.00	\$2,333.00
MS118-80	Plastic or Remote Reservoir, Black Anodized	\$2,845.00	\$2,560.00	\$2,418.00
MS118-80	Billet Aluminum Reservoir, Gloss or matte black	\$2,940.00	\$2,646.00	\$2,499.00
MS118-80	Billet Aluminum Reservoir, Black Anodized	\$3,060.00	\$2,754.00	\$2,601.00
LS CHEVY VVT, NO A/C				
MS118-82	Plastic or Remote Reservoir, Gloss or matte black	\$2,555.00	\$2,300.00	\$2,173.00
MS118-82	Plastic or Remote Reservoir, Black Anodized	\$2,655.00	\$2,390.00	\$2,257.00
MS118-82	Billet Aluminum Reservoir, Gloss or matte black	\$2,750.00	\$2,475.00	\$2,338.00
MS118-82	Billet Aluminum Reservoir, Black Anodized	\$2,870.00	\$2,583.00	\$2,440.00



FOR LS CHEVY

PART #	DESCRIPTION	RETAIL	JOBBER	DEALER
ELITE LS CHEVY				
MS118-60	Plastic or Remote Reservoir, Gloss or matte black	\$2,620.00	\$2,358.00	\$2,227.00
MS118-60	Plastic or Remote Reservoir, Black Anodized	\$2,720.00	\$2,448.00	\$2,312.00
MS118-60	Billet Aluminum Reservoir, Gloss or matte black	\$2,815.00	\$2,534.00	\$2,393.00
MS118-60	Billet Aluminum Reservoir, Black Anodized	\$2,935.00	\$2,642.00	\$2,495.00
ELITE LS CHEVY, NO A/C				
MS118-62	Plastic or Remote Reservoir, Gloss or matte black	\$2,430.00	\$2,187.00	\$2,066.00
MS118-62	Plastic or Remote Reservoir, Black Anodized	\$2,530.00	\$2,277.00	\$2,151.00
MS118-62	Billet Aluminum Reservoir, Gloss or matte black	\$2,625.00	\$2,363.00	\$2,231.00
MS118-62	Billet Aluminum Reservoir, Black Anodized	\$2,745.00	\$2,471.00	\$2,333.00
LS CHEVY				
MS118-90	Plastic or Remote Reservoir, Gloss or matte black	\$2,250.00	\$2,025.00	\$1,913.00
MS118-90	Plastic or Remote Reservoir, Black Anodized	\$2,350.00	\$2,115.00	\$1,998.00
MS118-90	Billet Aluminum Reservoir, Gloss or matte black	\$2,445.00	\$2,200.00	\$2,078.00
MS118-90	Billet Aluminum Reservoir, Black Anodized	\$2,565.00	\$2,309.00	\$2,180.00
LS CHEVY, NO A/C				
MS118-92	Plastic or Remote Reservoir, Gloss or matte black	\$2,060.00	\$1,854.00	\$1,751.00
MS118-92	Plastic or Remote Reservoir, Black Anodized	\$2,160.00	\$1,944.00	\$1,836.00
MS118-92	Billet Aluminum Reservoir, Gloss or matte black	\$2,255.00	\$2,030.00	\$1,917.00
MS118-92	Billet Aluminum Reservoir, Black Anodized	\$2,375.00	\$2,138.00	\$2,019.00



RAVEN S-DRIVE SERPENTINE PULLEY KIT FOR FORD

PART #	DESCRIPTION	RETAIL	JOBBER	DEALER
FORD SMALL BLOCK				
MS118-63	Plastic or Remote Reservoir, Gloss or matte black	\$2,475.00	\$2,471.00	\$2,333.00
MS118-63	Plastic or Remote Reservoir, Black Anodized	\$2,555.00	\$2,300.00	\$2,173.00
MS118-63	Billet Aluminum Reservoir, Gloss or matte black	\$2,670.00	\$2,403.00	\$2,270.00
MS118-63	Billet Aluminum Reservoir, Black Anodized	\$2,770.00	\$2,493.00	\$2,355.00
FORD SMALL BLOCK, NO POWER STEERING				
MS118-64	Plastic Reservoir, Gloss or matte black	\$2,325.00	\$2,093.00	\$1,976.00
MS118-64	Plastic Reservoir, Black Anodized	\$2,405.00	\$2,165.00	\$2,044.00
FORD SMALL BLOCK, NO A/C				
MS118-65	Plastic or Remote Reservoir, Gloss or matte black	\$2,300.00	\$2,070.00	\$1,955.00
MS118-65	Plastic or Remote Reservoir, Black Anodized	\$2,380.00	\$2,142.00	\$2,023.00
MS118-65	Billet Aluminum Reservoir, Gloss or matte black	\$2,495.00	\$2,246.00	\$2,121.00
MS118-65	Billet Aluminum Reservoir, Black Anodized	\$2,595.00	\$2,336.00	\$2,206.00
CLEVELAND FORD				
MS118-66	Plastic or Remote Reservoir, Gloss or matte black	\$2,050.00	\$1,845.00	\$1,743.00
MS118-66	Plastic or Remote Reservoir, Black Anodized	\$2,130.00	\$1,917.00	\$1,811.00
MS118-66	Billet Aluminum Reservoir, Gloss or matte black	\$2,245.00	\$2,021.00	\$1,908.00
MS118-66	Billet Aluminum Reservoir, Black Anodized	\$2,345.00	\$2,111.00	\$1,993.00

AS SEEN ON
CPP's
Comeback Camaro



1967 CAMARO

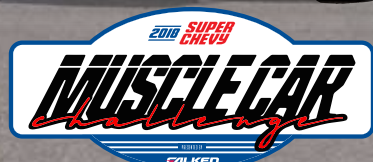

SCAN QR CODE:



SCAN QR CODE FOR MORE INFO ON ALL OF OUR OTHER BUILDS!



V-DRIVE V-BELT PULLEY SYSTEM

Eddie Motorsports' V Drive v-belt pulley kits include everything to accessorize your Chevy engine. Kits come complete with all of the necessary precision CNC machined billet aluminum brackets & pulleys, which are made in the USA, as well as high quality, name brand components; Tuff Stuff aluminum water pump, Sanden compact AC compressor, Maval power steering pump with attached plastic reservoir, Powermaster 170 amp alternator. Available in three black finishes and with natural or ALL BLACK finished components. Specify steering type in the order notes when placing your order (power steering gearbox or rack and pinion).



PART #	DESCRIPTION	RETAIL	JOBBER	DEALER
CHEVY SMALL BLOCK				
MS118-30	Remote Reservoir, Gloss or matte black	\$1,520.00	\$1,368.00	\$1,292.00
MS118-30	Plastic Reservoir, Gloss or matte black	\$1,600.00	\$1,440.00	\$1,360.00
MS118-30	Remote Reservoir Black Anodized	\$1,620.00	\$1,458.00	\$1,377.00
MS118-30	Plastic Reservoir, Black Anodized	\$1,700.00	\$1,530.00	\$1,445.00
MS118-30	Billet Aluminum Reservoir, Gloss or matte black	\$1,795.00	\$1,616.00	\$1,526.00
MS118-30	Billet Aluminum Reservoir, Black Anodized	\$1,915.00	\$1,724.00	\$1,628.00
CHEVY SMALL BLOCK, NO A/C				
MS118-32	Remote Reservoir, Gloss or matte black	\$1,370.00	\$1,233.00	\$1,165.00
MS118-32	Plastic Reservoir, Gloss or matte black	\$1,450.00	\$1,305.00	\$1,233.00
MS118-32	Remote Reservoir Black Anodized	\$1,470.00	\$1,323.00	\$1,250.00
MS118-32	Plastic Reservoir, Black Anodized	\$1,550.00	\$1,395.00	\$1,318.00
MS118-32	Billet Aluminum Reservoir, Gloss or matte black	\$1,645.00	\$1,481.00	\$1,398.00
MS118-32	Billet Aluminum Reservoir, Black Anodized	\$1,765.00	\$1,589.00	\$1,500.00
CHEVY BIG BLOCK				
MS118-95	Remote Reservoir, Gloss or matte black	\$1,570.00	\$1,413.00	\$1,335.00
MS118-95	Plastic Reservoir, Gloss or matte black	\$1,650.00	\$1,485.00	\$1,403.00
MS118-95	Remote Reservoir Black Anodized	\$1,670.00	\$1,503.00	\$1,420.00
MS118-95	Plastic Reservoir, Black Anodized	\$1,750.00	\$1,575.00	\$1,488.00
MS118-95	Billet Aluminum Reservoir, Gloss or matte black	\$1,845.00	\$1,661.00	\$1,568.00
MS118-95	Billet Aluminum Reservoir, Black Anodized	\$1,965.00	\$1,769.00	\$1,670.00
CHEVY BIG BLOCK, NO A/C				
MS118-97	Remote Reservoir, Gloss or matte black	\$1,420.00	\$1,278.00	\$1,207.00
MS118-97	Plastic Reservoir, Gloss or matte black	\$1,500.00	\$1,350.00	\$1,275.00
MS118-97	Remote Reservoir Black Anodized	\$1,520.00	\$1,368.00	\$1,292.00
MS118-97	Plastic Reservoir, Black Anodized	\$1,600.00	\$1,440.00	\$1,360.00
MS118-97	Billet Aluminum Reservoir, Gloss or matte black	\$1,695.00	\$1,526.00	\$1,441.00
MS118-97	Billet Aluminum Reservoir, Black Anodized	\$1,815.00	\$1,634.00	\$1,543.00

Classic Performance Products, Inc.

POPULAR UPGRADES / AIR CONDITIONING KITS

FOR CARS WITH FACTORY AIR CONDITIONING



GEN IV SURE FIT COMPLETE AC KIT

CPP now offers Vintage Air's most powerful and intelligent climate control system - the Gen IV Complete Kit! It features an exclusive electronic microprocessor control system that eliminates cables or vacuum connections. Utilizing a separate high capacity copper parallel-flow heat coil and aluminum plate and fin cooling coils, it delivers outstanding performance and instant temperature adjustment.

PART #	DESCRIPTION	RETAIL	JOBBER	DEALER
CHEVY TRUCK				
VA-944170	1967-72, kit	\$1,435.00	\$1,363.00	\$1,292.00
VA-944175	1973-80, kit	\$1,435.00	\$1,363.00	\$1,292.00
VA-944181	1981-87, kit	\$1,435.00	\$1,363.00	\$1,292.00
FORD CAR				
VA-954168	1967-68 Mustang, kit	\$1,395.00	\$1,325.00	\$1,256.00
VA-954170	1969-70 Mustang, kit	\$1,395.00	\$1,325.00	\$1,256.00
VA-951171	1967-68 Cougar, kit	\$1,395.00	\$1,325.00	\$1,256.00
IMPALA				
VA-964062	1961-62, kit	\$1,400.00	\$1,330.00	\$1,260.00
VA-964063	1963, kit	\$1,400.00	\$1,330.00	\$1,260.00
VA-964064	1964, kit	\$1,400.00	\$1,330.00	\$1,260.00
CAMARO				
VA-964167	1967-68, kit	\$1,480.00	\$1,406.00	\$1,332.00
VA-964169	1969, kit	\$1,480.00	\$1,406.00	\$1,332.00
VA-965070	1970-73, kit	\$1,395.00	\$1,325.00	\$1,256.00
VA-965073	1974-77, kit	\$1,395.00	\$1,325.00	\$1,256.00
VA-965078	1978, kit	\$1,395.00	\$1,325.00	\$1,256.00
VA-965080	1979-81, kit	\$1,395.00	\$1,325.00	\$1,256.00
FIREBIRD				
VA-964167	1967-68, kit	\$1,480.00	\$1,406.00	\$1,332.00
VA-964468	1969, kit	\$1,435.00	\$1,363.00	\$1,292.00
VA-964080	1970-81, kit	\$1,480.00	\$1,406.00	\$1,332.00

NOTES:

- Some installations may require additional engine pulleys not included with kits. You must provide pulleys, V-belts, heater hose and refrigerant.
- SureFit systems may interfere with some OEM radios or in-dash speakers.
- We recommend using a heavy-duty fan blade and a fan shroud.

1960-66 Chevy Trucks - The supplied firewall fill-plate is designed for non-air trucks. OEM air equipped trucks will require a larger cover plate (not currently available).

1968 Cutlass - 442 with cowl induction hood will require the use of our rear exit compressor.

COMPLETE KIT FEATURES:

* Contents may vary between applications.

- Evaporator and mounting bracket
- Louvers (when required)
- Duct Hose
- Wiring Harness
- Hardware and Installation Manual
- New Controls or Cable Converters
- Compressor
- Engine Brackets
- Condenser with brackets
- Pre-formed Refrigerant Lines
- Drier
- Fittings

PART #	DESCRIPTION	RETAIL	JOBBER	DEALER
NOVA/CHEVY II				
VA-965069	1968, kit	\$1,379.00	\$1,310.00	\$1,241.00
VA-965072	1969-72, kit	\$1,395.00	\$1,325.00	\$1,256.00
GM "A"-BODY				
VA-964464	1964-65 Chevelle, kit	\$1,395.00	\$1,325.00	\$1,256.00
VA-964465	1966-67 Chevelle, kit	\$1,395.00	\$1,325.00	\$1,256.00
VA-964471	1968-69 Chevelle, kit	\$1,395.00	\$1,325.00	\$1,256.00
VA-965071	1970-72 Chevelle, kit	\$1,395.00	\$1,325.00	\$1,256.00
VA-964069	1968 Cutlass, kit	\$1,395.00	\$1,325.00	\$1,256.00
VA-964069	1969 Cutlass, kit	\$1,395.00	\$1,325.00	\$1,256.00
VA-964171	1970-72 Cutlass, kit	\$1,395.00	\$1,325.00	\$1,256.00
VA-964467	1964-67 GTO, kit	\$1,435.00	\$1,363.00	\$1,292.00
MOPAR				
VA-974074-EDU	1970-74 Challenger, std gauges, kit	\$1,395.00	\$1,325.00	\$1,256.00
VA-974073-EDU	1970-74 Challenger, Rallye gauges, kit	\$1,395.00	\$1,325.00	\$1,256.00
VA-971067	1966-67 Coronet, Chrgr, kit	\$1,450.00	\$1,378.00	\$1,305.00
VA-971061	1966-67 Belvedere, Satellite, GTX, kit	\$1,450.00	\$1,378.00	\$1,305.00
VA-971063	1968 Rd Rnr, Satellite, GTX, Coronet, Super Bee, Chrgr, kit	\$1,450.00	\$1,378.00	\$1,305.00
VA-971065	1969-70 Rd Rnr, Satellite, GTX, Coronet, Super Bee, Chrgr, kit	\$1,450.00	\$1,378.00	\$1,305.00

Tri-Five - Standard Sure fit condenser kits designed for original style core support and vertical flow radiators. Condenser hard lines route through core support (specify V8 - Radiator mounted behind core support, or 6-cylinder - Radiator mounted in front of core support) position. If using cross flow radiator, condenser must be matched to core size and additional fittings and refrigerant hose may be required.

Tri-Five - kit designed for original "non A/C" firewall and dash.

Tri-Five - If you are retaining the original 265 or 283 V8 engine in your car, you may need to upgrade the harmonic balancer and pulleys. You will also need to upgrade from the generator to an alternator.

FOR CARS WITHOUT FACTORY AIR CONDITIONING



1947-49 CHEVY TRUCK



PART #	DESCRIPTION	RETAIL	JOBBER	DEALER
CHEVY TRUCK				
VA-941852	1947-49, V8 swap, kit	\$1,435.00	\$1,363.00	\$1,292.00
VA-941858	1947-49, Dlx, 6-cyl., kit	\$1,738.00	\$1,651.00	\$1,564.00
VA-941853	1950-53, V8 swap, kit	\$1,362.00	\$1,294.00	\$1,226.00
VA-941859	1950-53, Dlx, 6-cyl., kit	\$1,727.00	\$1,641.00	\$1,554.00
VA-941854	1954-55, V8 swap, kit (early 1955)	\$1,435.00	\$1,363.00	\$1,292.00
VA-941860	1954-55, Dlx, 6-cyl., kit (early 1955)	\$1,738.00	\$1,651.00	\$1,564.00
VA-941155	1955-57, Std. controls, kit (late 1955)	\$1,435.00	\$1,363.00	\$1,292.00
VA-941156	1955-57, Dlx controls, kit (late 1955)	\$1,550.00	\$1,473.00	\$1,395.00
VA-941158	1958-59, Dlx Ctrl, kit	\$1,500.00	\$1,425.00	\$1,350.00
VA-941157	1958-59, Std Ctrl, kit	\$1,435.00	\$1,363.00	\$1,292.00
VA-941160	1960-63, kit	\$1,435.00	\$1,363.00	\$1,292.00
VA-941164	1964-66, OEM Dlx Ctrl, kit	\$1,363.00	\$1,295.00	\$1,227.00
VA-941165	1964-66, Rotary Ctrl, kit	\$1,363.00	\$1,295.00	\$1,227.00
VA-941170	1967-72, kit	\$1,435.00	\$1,363.00	\$1,292.00
VA-941171	1967-72, using Factory AC panel, kit	\$1,435.00	\$1,363.00	\$1,292.00
VA-941175	1973-80, kit	\$1,435.00	\$1,363.00	\$1,292.00
VA-941181	1981-87, kit	\$1,435.00	\$1,363.00	\$1,292.00
FORD CAR				
VA-954164	1964-1/2-66 Mustang, kit	\$1,395.00	\$1,325.00	\$1,256.00
VA-951168	1967-68 Mustang, kit	\$1,395.00	\$1,325.00	\$1,256.00
VA-951170	1969-70 Mustang, kit	\$1,395.00	\$1,325.00	\$1,256.00
VA-951169	1967-68 Cougar, kit	\$1,395.00	\$1,325.00	\$1,256.00
VA-954150	1964-65 Falcon, kit	\$1,480.00	\$1,406.00	\$1,332.00
FORD TRUCK				
VA-74053-LFU-A	1953-55, kit	\$1,275.00	\$1,211.00	\$1,148.00
VA-74056-LFU-A	1956, kit	\$1,229.00	\$1,168.00	\$1,106.00
VA-951153	1961-64, 6-cyl., kit	\$1,525.00	\$1,449.00	\$1,373.00
VA-951150	1961-64, V8, kit	\$1,450.00	\$1,378.00	\$1,305.00
VA-951154	1965, 6-cyl., kit	\$1,510.00	\$1,435.00	\$1,359.00
VA-951151	1965, V8, kit	\$1,450.00	\$1,378.00	\$1,305.00
VA-951155	1966, 6-cyl., kit	\$1,510.00	\$1,435.00	\$1,359.00
VA-951152	1966, V8, kit	\$1,450.00	\$1,378.00	\$1,305.00
CHEVY FULLSIZE				
VA-96156-PCU	1955-56, 4-vent, kit	\$1,395.00	\$1,325.00	\$1,256.00
VA-96155-PCU	1955-56, center vent, kit	\$1,395.00	\$1,325.00	\$1,256.00
VA-965701	1957, center vent, kit	\$1,330.00	\$1,264.00	\$1,197.00
VA-965702	1957, 4-vent, kit	\$1,330.00	\$1,264.00	\$1,197.00

PART #	DESCRIPTION	RETAIL	JOBBER	DEALER
IMPALA				
VA-961055	1959-60, 2-lever, kit	\$1,400.00	\$1,330.00	\$1,260.00
VA-961056	1959-60, 4-lever, kit	\$1,435.00	\$1,363.00	\$1,292.00
VA-961062	1961-62, kit	\$1,400.00	\$1,330.00	\$1,260.00
VA-961063	1963, kit	\$1,400.00	\$1,330.00	\$1,260.00
VA-961064	1964, kit	\$1,400.00	\$1,330.00	\$1,260.00
CAMARO				
VA-961167	1967-68, kit	\$1,480.00	\$1,406.00	\$1,332.00
VA-961169	1969, kit	\$1,480.00	\$1,406.00	\$1,332.00
VA-961170	1970-73, kit	\$1,395.00	\$1,325.00	\$1,256.00
VA-961173	1974-77, kit	\$1,395.00	\$1,325.00	\$1,256.00
VA-961178	1978, kit	\$1,395.00	\$1,325.00	\$1,256.00
VA-961180	1979-81, kit	\$1,395.00	\$1,325.00	\$1,256.00
FIREBIRD				
VA-961167	1967-68, kit	\$1,480.00	\$1,406.00	\$1,332.00
VA-961168	1969, kit	\$1,435.00	\$1,363.00	\$1,292.00
VA-961080	1970-81, kit	\$1,480.00	\$1,406.00	\$1,332.00
NOVA/CHEVY II				
VA-961164	1962-65, kit	\$1,480.00	\$1,406.00	\$1,332.00
VA-961166	1966-67, kit	\$1,395.00	\$1,325.00	\$1,256.00
VA-961069	1968, kit	\$1,379.00	\$1,310.00	\$1,241.00
VA-961072	1969-72, kit	\$1,395.00	\$1,325.00	\$1,256.00
GM A-BODY				
VA-961065	1964-65 Chevelle, kit	\$1,395.00	\$1,325.00	\$1,256.00
VA-961066	1966-67 Chevelle, kit	\$1,395.00	\$1,325.00	\$1,256.00
VA-961068	1968-69 Chevelle, kit	\$1,395.00	\$1,325.00	\$1,256.00
VA-961071	1970-72 Chevelle, kit	\$1,395.00	\$1,325.00	\$1,256.00
VA-961061	1968 Cutlass, kit	\$1,395.00	\$1,325.00	\$1,256.00
VA-961074	1969 Cutlass, kit	\$1,395.00	\$1,325.00	\$1,256.00
VA-961076	1970-72 Cutlass, kit	\$1,395.00	\$1,325.00	\$1,256.00
VA-961067	1964-67 GTO, kit	\$1,435.00	\$1,363.00	\$1,292.00
MOPAR				
VA-971074-EDU	1970-74 Challenger, std gauges, kit	\$1,395.00	\$1,325.00	\$1,256.00
VA-971074-EDU	1970-74 Challenger, Rallye gauges, kit	\$1,395.00	\$1,325.00	\$1,256.00
VA-971066	1966-67 Coronet, Chrgr, kit	\$1,450.00	\$1,378.00	\$1,305.00
VA-971060	1966-67 Belvedere, Satellite, GTX, kit	\$1,450.00	\$1,378.00	\$1,305.00
VA-971062	1968 Rd Rnr, Satellite, GTX, Coronet, Super Bee, Chrgr, kit	\$1,450.00	\$1,378.00	\$1,305.00
VA-971064	1969-70 Rd Rnr, Satellite, GTX, Coronet, Super Bee, Chrgr, kit	\$1,450.00	\$1,378.00	\$1,305.00

Classic Performance Products, Inc.

POPULAR UPGRADES / EVAPORATOR KITS

FOR CARS WITH FACTORY AIR CONDITIONING



KIT FEATURES:

- Evaporator and mounting bracket
- Louvers (when required)
- Duct Hose
- Wiring Harness
- New Controls or Cable Converters
- Hardware and Installation Manual
- Factory compressor or aftermarket setup

* Contents may vary between applications



1964-65 CHEVELLE

GEN IV SURE FIT EVAPORATOR KIT

PART #	DESCRIPTION	RETAIL	JOBBER	DEALER
CHEVY TRUCK				
VA-754170	1967-72, kit	\$790.00	\$751.00	\$711.00
VA-754175	1973-80, kit	\$790.00	\$751.00	\$711.00
VA-754181	1981-87, kit	\$790.00	\$751.00	\$711.00
FORD CAR				
VA-554168	1967-68 Mustang, kit	\$780.00	\$741.00	\$702.00
VA-554170	1969-70 Mustang, kit	\$780.00	\$741.00	\$702.00
VA-554168	1967-68 Cougar, kit	\$780.00	\$741.00	\$702.00
IMPALA				
VA-564062	1961-62, kit	\$780.00	\$741.00	\$702.00
VA-564063	1963, kit	\$780.00	\$741.00	\$702.00
VA-564064	1964, kit	\$780.00	\$741.00	\$702.00
CAMARO				
VA-564190	1967-68, kit	\$835.00	\$793.00	\$752.00
VA-564169	1969, kit	\$780.00	\$741.00	\$702.00
VA-565073	1970-73, kit	\$780.00	\$741.00	\$702.00
VA-565073	1974-77, kit	\$780.00	\$741.00	\$702.00
VA-565073	1978, kit	\$780.00	\$741.00	\$702.00
VA-565080	1979-81, kit	\$780.00	\$741.00	\$702.00
FIREBIRD				
VA-564190	1967-68, kit	\$835.00	\$793.00	\$752.00
VA-564468	1969, kit	\$780.00	\$741.00	\$702.00
VA-564150	1970-81, kit	\$835.00	\$793.00	\$752.00

PART #	DESCRIPTION	RETAIL	JOBBER	DEALER
NOVA/CHEVY II				
VA-565069	1968, kit	\$769.00	\$731.00	\$692.00
VA-565072	1969-72, kit	\$780.00	\$741.00	\$702.00
GM A-BODY				
VA-564464	1964-65 Chevelle, kit	\$780.00	\$741.00	\$702.00
VA-564466	1966-67 Chevelle, kit	\$780.00	\$741.00	\$702.00
VA-564471	1968-69 Chevelle, kit	\$780.00	\$741.00	\$702.00
VA-565071	1970-72 Chevelle, kit	\$780.00	\$741.00	\$702.00
VA-564069	1968 Cutlass, kit	\$769.00	\$731.00	\$692.00
VA-564069	1969 Cutlass, kit	\$769.00	\$731.00	\$692.00
VA-564171	1970-72 Cutlass, kit	\$780.00	\$741.00	\$702.00
VA-564467	1964-67 GTO, kit	\$790.00	\$751.00	\$711.00
MOPAR				
VA-574074-EDZ	1970-74 Challenger, std gauges, kit	\$780.00	\$741.00	\$702.00
VA-574073-EDZ	1970-74 Challenger, Rallye gauges, kit	\$780.00	\$741.00	\$702.00
VA-571067	1966-67 Coronet, Chrgr, kit	\$780.00	\$741.00	\$702.00
VA-571061	1966-67 Belvedere, Satellite, GTX, kit	\$835.00	\$793.00	\$752.00
VA-571063	1968 Rd Rnr, Satellite, GTX, Coronet, Super Bee, Chrgr, kit	\$835.00	\$793.00	\$752.00
VA-571065	1969-70 Rd Rnr, Satellite, GTX, Coronet, Super Bee, Chrgr, kit	\$835.00	\$793.00	\$752.00

HEATER HOSES

These universal heater hoses feature 90 degree ends help to ensure cleaner and better looking plumbing when adding an electric heater valve used in modern AC upgrades.

PART #	DESCRIPTION	RETAIL	JOBBER	DEALER
28473	90° 5/8 Heater Hose 4x60"	\$25.00	\$23.00	\$21.00
28466	90° 5/8 Heater Hose 4x6"	\$25.00	\$23.00	\$21.00
18074	90° 3/4" Reduced to 5/8" Heater Hose	\$25.00	\$23.00	\$21.00
18084	90° 3/4" Reduced to 5/8" Heater Hose, 60" length	\$25.00	\$23.00	\$21.00



FOR CARS WITHOUT FACTORY AIR CONDITIONING



1970-78 CAMARO

PART #	DESCRIPTION	RETAIL	JOBBER	DEALER
CHEVY TRUCK				
VA-754561	1947-49, V8 swap, kit	\$819.00	\$778.00	\$737.00
VA-754561	1947-49, Dlx, 6-cyl., kit	\$819.00	\$778.00	\$737.00
VA-754562	1950-53, V8 swap, kit	\$819.00	\$778.00	\$737.00
VA-754562	1950-53, Dlx, 6-cyl., kit	\$819.00	\$778.00	\$737.00
VA-754563	1954-55, V8 swap, kit (early 1955)	\$780.00	\$741.00	\$702.00
VA-754563	1954-55, Dlx, 6-cyl., kit (early 1955)	\$780.00	\$741.00	\$702.00
VA-751156	1955-59, Dlx Ctrl Ctrl, kit (late 1955)	\$949.00	\$902.00	\$854.00
VA-751155	1955-59, Std controls, kit (late 1955)	\$790.00	\$751.00	\$711.00
VA-751163	1960-63, kit	\$780.00	\$741.00	\$702.00
VA-751164	1964-66, OEM Dlx Ctrl, kit	\$790.00	\$751.00	\$711.00
VA-751165	1964-66, Rotary Ctrl, kit	\$790.00	\$751.00	\$711.00
VA-751170	1967-72, kit	\$790.00	\$751.00	\$711.00
VA-751171	1967-72, using Factory AC panel, kit	\$790.00	\$751.00	\$711.00
VA-751175	1973-80, kit	\$790.00	\$751.00	\$711.00
VA-751181	1981-87, kit	\$790.00	\$751.00	\$711.00
FORD CAR				
VA-554164	1964-1/2-66 Mustang, kit	\$780.00	\$741.00	\$702.00
VA-551168	1967-68 Mustang, kit	\$780.00	\$741.00	\$702.00
VA-551170	1969-70 Mustang, kit	\$780.00	\$741.00	\$702.00
VA-551168	1967-68 Cougar, kit	\$780.00	\$741.00	\$702.00
VA-554150	1964-65 Falcon, kit	\$780.00	\$741.00	\$702.00
FORD TRUCK				
VA-75453-LFZ-A	1953-55, kit	\$645.00	\$613.00	\$581.00
VA-75456-LFZ-A	1956, kit	\$645.00	\$613.00	\$581.00
VA-754150	1961-64, 6-cyl., kit	\$835.00	\$793.00	\$752.00
VA-754150	1961-64, V8, kit	\$835.00	\$793.00	\$752.00
VA-754151	1965, 6-cyl., kit	\$835.00	\$793.00	\$752.00
VA-754151	1965, V8, kit	\$835.00	\$793.00	\$752.00
VA-754151	1966, 6-cyl., kit	\$835.00	\$793.00	\$752.00
VA-754151	1966, V8, kit	\$835.00	\$793.00	\$752.00
CHEVY FULLSIZE				
VA-56156-PCZ	1955-56, 4-vent, kit	\$780.00	\$741.00	\$702.00
VA-56155-PCZ	1955-56, center vent, kit	\$780.00	\$741.00	\$702.00
VA-565701	1957, center vent, kit	\$780.00	\$741.00	\$702.00
VA-565702	1957, 4-vent, kit	\$780.00	\$741.00	\$702.00

PART #	DESCRIPTION	RETAIL	JOBBER	DEALER
IMPALA				
VA-561055	1959-60, 2-lever, kit	\$780.00	\$741.00	\$702.00
VA-561056	1959-60, 4-lever, kit	\$780.00	\$741.00	\$702.00
VA-561062	1961-62, kit	\$780.00	\$741.00	\$702.00
VA-561063	1963, kit	\$780.00	\$741.00	\$702.00
VA-561064	1964, kit	\$780.00	\$741.00	\$702.00
CAMARO				
VA-561190	1967-68, kit	\$835.00	\$793.00	\$752.00
VA-561169	1969, kit	\$780.00	\$741.00	\$702.00
VA-561173	1970-73, kit	\$780.00	\$741.00	\$702.00
VA-561173	1974-77, kit	\$780.00	\$741.00	\$702.00
VA-561173	1978, kit	\$780.00	\$741.00	\$702.00
VA-561180	1979-81, kit	\$780.00	\$741.00	\$702.00
FIREBIRD				
VA-561190	1967-68, kit	\$835.00	\$793.00	\$752.00
VA-561168	1969, kit	\$780.00	\$741.00	\$702.00
VA-561150	1970-81, kit	\$835.00	\$793.00	\$752.00
NOVA/CHEVY II				
VA-561164	1962-65, kit	\$780.00	\$741.00	\$702.00
VA-561166	1966-67, kit	\$780.00	\$741.00	\$702.00
VA-561069	1968, kit	\$769.00	\$731.00	\$692.00
VA-561072	1969-72, kit	\$780.00	\$741.00	\$702.00
GM A-Body				
VA-561065	1964-65 Chevelle, kit	\$780.00	\$741.00	\$702.00
VA-561066	1966-67 Chevelle, kit	\$780.00	\$741.00	\$702.00
VA-561068	1968-69 Chevelle, kit	\$780.00	\$741.00	\$702.00
VA-561071	1970-72 Chevelle, kit	\$780.00	\$741.00	\$702.00
VA-561061	1968 Cutlass, kit	\$769.00	\$731.00	\$692.00
VA-561070	1969 Cutlass, kit	\$769.00	\$731.00	\$692.00
VA-561076	1970-72 Cutlass, kit	\$780.00	\$741.00	\$702.00
VA-561067	1964-67 GTO, kit	\$790.00	\$751.00	\$711.00
Mopar				
VA-571074-EDZ	1970-74 Challenger, std gauges, kit	\$780.00	\$741.00	\$702.00
VA-571074-EDZ	1970-74 Challenger, Rallye gauges, kit	\$780.00	\$741.00	\$702.00
VA-571066	1966-67 Coronet, Chrgr, kit	\$780.00	\$741.00	\$702.00
VA-571060	1966-67 Belvedere, Satellite, GTX, kit	\$835.00	\$793.00	\$752.00
VA-571062	1968 Rd Rnr, Satellite, GTX, Coronet, Super Bee, Chrgr, kit	\$835.00	\$793.00	\$752.00
VA-571064	1969-70 Rd Rnr, Satellite, GTX, Coronet, Super Bee, Chrgr, kit	\$835.00	\$793.00	\$752.00

Classic Performance Products, Inc.

POPULAR UPGRADES / RADIATOR KITS



NOW AVAILABLE!



#DR6139013A



#DR6239003A

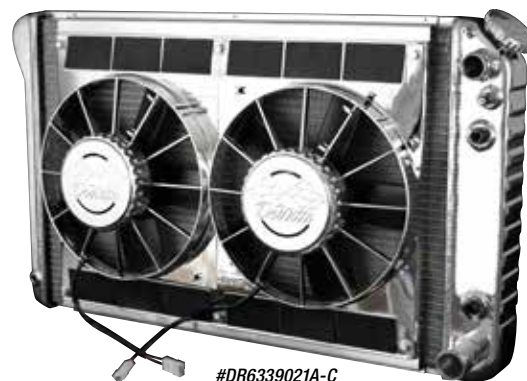

#DR6339021A-C

DEWITTS DIRECT-FIT™ LSX ALUMINUM RADIATOR CONVERSION KITS

Direct-Fit radiators for vehicles with LS engines with manual transmissions. Inlet and outlet are on the passenger side. Features factory type press formed end tanks, dual row core, and serpentine fins. Provide 30% more cooling than the stock copper unit at half the weight. 1955-57 Chevy Fullsize cars feature a 16" single-spall fan, all other applications feature an 11" dual-spall fan. It is epoxy free, and will fit into the stock core support. Aluminum plate style coolers will offer twice the cooling of the OE Copper style coolers. Transmission cooler is located on the passenger side. DeWitts is the only manufacturer that can integrate an internal dual-flow cooler. For automatic transmission, use A instead of M for part number (\$30 upgrade).

APPLICATIONS:

- ALL POPULAR

FEATURES INCLUDE*

- 2 Rows of 1" Tubes
- Single or Dual Fans
- Billet Dewitt's Cap
- Stem Line
- Relays
- Wiring
- Aluminum Plate Cooler with 3/8" Npt Port Threads
- Temp Sensor in the Radiator
- Jiffy-Tite Quick Connect Fittings



PART #	DESCRIPTION	RETAIL	JOBBER	DEALER
PLAIN FINISH				
DR6139017M	1963-66 Chevy Truck	\$1,050.00	\$998.00	\$945.00
DR6139018M	1967-87 Chevy Truck	\$1,050.00	\$998.00	\$945.00
DR6139013M	1955-57 Chevy Car 6 cyl position	\$890.00	\$846.00	\$801.00
DR6139012M	1955-57 Chevy Car 8 cyl position	\$890.00	\$846.00	\$801.00
DR6139015M	1959-62 Fullsize	\$1,050.00	\$998.00	\$945.00
DR6139016M	1963-70 Fullsize	\$1,050.00	\$998.00	\$945.00
DR6139010M	1962-67 Nova	\$1,050.00	\$998.00	\$945.00
DR6139011M	1968-72 Nova	\$890.00	\$846.00	\$801.00
DR6139022M	1967-69 Camaro	\$1,050.00	\$998.00	\$945.00
DR6139005M	1970-81 Camaro	\$1,050.00	\$998.00	\$945.00
DR6139021M	1970-81 Firebird	\$1,050.00	\$998.00	\$945.00
DR6139002M	1964-67 Chevelle	\$1,050.00	\$998.00	\$945.00
DR6139003M	1968-72 Chevelle	\$1,050.00	\$998.00	\$945.00
DR6139005M	1978-87 G Body	\$1,050.00	\$998.00	\$945.00
BLACK ICE FINISH				
DR6239017M	1963-66 Chevy Truck	\$1,110.00	\$1,055.00	\$998.00
DR6239018M	1967-87 Chevy Truck	\$1,110.00	\$1,055.00	\$998.00
DR6239013M	1955-57 Chevy Car 6 cyl position	\$949.00	\$903.00	\$854.00
DR6239012M	1955-57 Chevy Car 8 cyl position	\$949.00	\$903.00	\$854.00
DR6239015M	1959-62 Fullsize	\$1,110.00	\$1,055.00	\$998.00
DR6239016M	1963-70 Fullsize	\$1,110.00	\$1,055.00	\$998.00
DR6239010M	1962-67 Nova	\$1,110.00	\$1,055.00	\$998.00
DR6239011M	1968-72 Nova	\$949.00	\$903.00	\$854.00
DR6239022M	1967-69 Camaro	\$1,110.00	\$1,055.00	\$998.00
DR6239005M	1970-81 Camaro	\$1,110.00	\$1,055.00	\$998.00
DR6239021M	1970-81 Firebird	\$1,110.00	\$1,055.00	\$998.00
DR6239002M	1964-67 Chevelle	\$1,110.00	\$1,055.00	\$998.00
DR6239003M	1968-72 Chevelle	\$1,110.00	\$1,055.00	\$998.00
DR6239005M	1978-87 G Body	\$1,110.00	\$1,055.00	\$998.00

PART #	DESCRIPTION	RETAIL	JOBBER	DEALER
POLISHED FINISH				
DR6339017M	1963-66 Chevy Truck	\$1,310.00	\$1,245.00	\$1,179.00
DR6339018M	1967-87 Chevy Truck	\$1,310.00	\$1,245.00	\$1,179.00
DR6339013M	1955-57 Chevy Car 6 cyl position	\$1,150.00	\$1,093.00	\$1,035.00
DR6339012M	1955-57 Chevy Car 8 cyl position	\$1,150.00	\$1,093.00	\$1,035.00
DR6339015M	1959-62 Fullsize	\$1,310.00	\$1,245.00	\$1,179.00
DR6339016M	1963-70 Fullsize	\$1,310.00	\$1,245.00	\$1,179.00
DR6339010M	1962-67 Nova	\$1,310.00	\$1,245.00	\$1,179.00
DR6339011M	1968-72 Nova	\$1,150.00	\$1,093.00	\$1,035.00
DR6339022M	1967-69 Camaro	\$1,310.00	\$1,245.00	\$1,179.00
DR6339005M	1970-81 Camaro	\$1,310.00	\$1,245.00	\$1,179.00
DR6339021M	1970-81 Firebird	\$1,310.00	\$1,245.00	\$1,179.00
DR6339002M	1964-67 Chevelle	\$1,310.00	\$1,245.00	\$1,179.00
DR6339003M	1968-72 Chevelle	\$1,310.00	\$1,245.00	\$1,179.00
DR6339005M	1978-87 G Body	\$1,310.00	\$1,245.00	\$1,179.00



#AT90-150-CLR-2



#HTSEC90-125-BLK

RADIATOR PLUMBING HOSES

Our radiator plumbing hoses are now available specifically for LS conversions in mind. These 90 degree, 16-gauge aluminum tubes in 1.25 and 1.50" OD allows for a neat and clean installation when coupled with the 4-ply reinforced silicone ends. Both parts can be trimmed and fitted for an easy installation. Upper Radiator connections will use the 1.25" OD while most lower hose kits use 1.5" OD.

PART #	DESCRIPTION	RETAIL	JOBBER	DEALER
AT90-125-CLR-2	1.25" ID 90 Degree Bend Aluminum Tube, 16 Gauge W/6" Leg & 2" Cir	\$23.00	\$21.00	\$20.00
AT90-150-CLR-2	1.5" ID 90 Degree Bend Aluminum Tubing 16 Gauge W/6" Leg & 2" Cir	\$27.00	\$25.00	\$23.00
HTSEC90-125-BLK	1.25" ID 90 Deg Bend Black Elbow Coupler, 4-Ply Reinforced Silicone	\$24.00	\$22.00	\$21.00
HTSEC90-150-BLK	1.50" ID 90 Deg Bend Black Elbow Coupler, 4-Ply Reinforced Silicone	\$26.00	\$24.00	\$23.00



#AR-E-57-LS



#AR-E-57-LS

AUTORAD RADIATORS

These complete core support and radiator assemblies designed and built by AutoRad feature all aluminum construction including aluminum crossflow radiators and aluminum shrouds with dual 14" fans. Available for small block, big block and LS applications, these units feature stainless steel hardware and come with overflow tanks (with caps) and are available with optional built-in A/C condensers and external transmission coolers. These units are modular, so the optional A/C condensers and transmission coolers can always be added later without any modifications. Best of all, these are made in the USA and backed by a 2 year warranty from the manufacturer.

PART #	DESCRIPTION	RETAIL	JOBBER	DEALER
RADIATOR WITH END PANELS AND BOTTOM PANEL				
AR-E-55-CM		\$1,350.00	\$1,289.00	\$1,219.00
AR-E-57-CM		\$1,350.00	\$1,289.00	\$1,219.00
AR-E-55-LS		\$1,350.00	\$1,289.00	\$1,219.00
AR-E-57-LS		\$1,350.00	\$1,289.00	\$1,219.00

PART #	DESCRIPTION	RETAIL	JOBBER	DEALER
RADIATOR ACCESSORIES				
AR-E-AC	AC Conditioner	\$200.00	\$190.00	\$180.00
AR-E-TC	External Trans Cooler	\$100.00	\$90.00	\$80.00
AR-RADCAP		\$49.00	\$45.00	\$40.00

TRANS-SAVER SERIES COOLERS

Designed to cool any vehicle fluids including automatic transmission fluid, power steering fluid, engine oil, engine coolant, fuel and street hydraulics. Available in single or dual pass and in polished or plain finish. Specify when ordering.

PART #	DESCRIPTION	RETAIL	JOBBER	DEALER
CP0050	12" Chrome Single Pass, each	\$48.00	\$46.00	\$44.00
CP0052	18" Chrome Single Pass, each	\$55.00	\$52.00	\$48.00
CP0054	12" Chrome Dual Pass, each	\$55.00	\$52.00	\$48.00
CP0056	18" Chrome Dual Pass, each	\$75.00	\$67.00	\$58.00

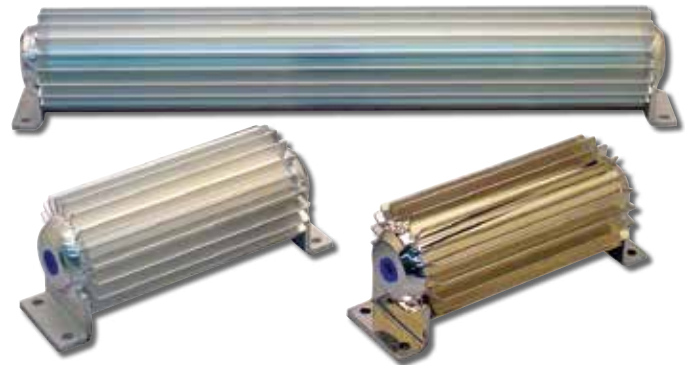

ENGINE COOLANT RECOVERY KIT

Our coolant recovery kits are easy to install and constructed from high-quality plastic material for long-lasting durability. Kit includes plastic coated wire bracket and all necessary mounting hardware and plumbing needs. Capacity of 18 fl. oz.

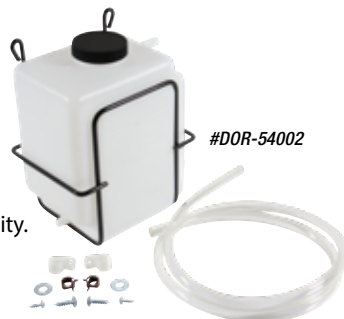

#DOR-54002

PART #	DESCRIPTION	RETAIL	JOBBER	DEALER
DOR-54002	kit	\$18.00	\$17.00	\$15.00

STAINLESS STEEL RADIATOR OVERFLOW TANK



PART #	DESCRIPTION	RETAIL	JOBBER	DEALER
CP6079A	12" Chrome Single Pass, each	\$36.00	\$34.00	\$31.00
CP6075A	18" Chrome Single Pass, each	\$37.00	\$35.00	\$32.00
CP6073A	12" Chrome Dual Pass, each	\$35.00	\$33.00	\$30.00

Classic Performance Products, Inc.

POPULAR UPGRADES / DIGITAL GAUGE CONVERSIONS



NOW AVAILABLE AT CPP!

1963 NOVA



1953 CHEVY CAR



1947 CHEVY TRUCK



1965 MUSTANG

SERIES III INSTRUMENT SYSTEMS

Dakota Digital Series III instrument systems offer the latest technologies and features for your custom vehicle. High brightness vacuum fluorescent displays provide a lifetime of trouble free use while offering increased accuracy and features! Dash bezel is available in camera case, wood grain or GT-style. Gauges are available in blue or teal lettering.

** Call for specific applications

starting at

PART #	DESCRIPTION	RETAIL	JOBBER	DEALER
VFD3-**C-PU-*	1947-72 Chevy Truck	\$566.00	\$537.70	\$509.40
VFD3-**F-*	1949-53 Ford Car	\$604.00	\$573.80	\$543.60
VFD3-**M-*	1965-70 Ford Mustang	\$594.00	\$573.80	\$543.60
VFD3-**F-PU-*	1948-87 Ford Truck	\$594.00	\$573.80	\$543.60
VFD3-**C-*	1941-57 Chevy Car	\$566.00	\$537.70	\$509.40
VFD3-**C-CAM-*	1967-81 Camaro	\$594.00	\$573.80	\$543.60
VFD3-**P-FIR-*	1967-69 Firebird	\$566.00	\$537.70	\$509.40
VFD3-**C-IMP-*	1959-70 Impala	\$632.00	\$600.40	\$568.80
VFD3-**C-NOV-*	1963-76 Nova	\$661.00	\$627.95	\$594.90
VFD3-**C-CVL-*	1964-72 Chevelle	\$727.00	\$690.65	\$654.30
VFD3-**C-MC-*	1981-88 Monte Carlo	\$689.00	\$654.55	\$620.10
VFD3-**B-REG-*	1984-87 Regal	\$689.00	\$654.55	\$620.10
VFD3-**M-*	1950-51 Mercury	\$689.00	\$654.55	\$620.10

HDX INSTRUMENT SYSTEMS

Available with your choice of black or silver alloy gauge-face styling, each HDX system allows the user to select independent illumination colors for the gauge readings and needles, as well as the message centers. Calibration and personal settings are manipulated with the built-in, capacitive-touch buttons, or the available Bluetooth app for Apple and Android devices. Each needle hub is black nickel plated spun-aluminum to match the buttons. All HDX instrument systems feature dead-faced indicators (turn signals, high beam, check engine, cruise control, parking brake, plus two user-definable), and a red, settable warning light for each gauge. With our central control box, installation is greatly simplified with vehicle-harness sourced signals and supplied, solid state sending units connecting cleanly to their respective terminal.

** Call for specific applications

starting at

PART #	DESCRIPTION	RETAIL	JOBBER	DEALER
HDX-**C-PU	1947-87 Chevy Truck	\$1,231.00	\$1,169.45	\$1,107.90
HDX-**F-PU	1953-72 Ford Truck	\$1,231.00	\$1,169.45	\$1,107.90
HDX-**F-MUS	1965-70 Mustang	\$1,231.00	\$1,169.45	\$1,107.90
HDX-**C	1953-57 Chevy Car	\$1,231.00	\$1,169.45	\$1,107.90
HDX-**C-IMP	1959-64 Impala	\$1,231.00	\$1,169.45	\$1,107.90
HDX-**C-NOV	1963-76 Nova	\$1,231.00	\$1,169.45	\$1,107.90
HDX-**C-CAM	1967-81 Camaro	\$1,231.00	\$1,169.45	\$1,107.90
HDX-**C-CVL	1964-72 Chevelle	\$1,231.00	\$1,169.45	\$1,107.90
HDX-**C-MAL	1970-72 Malibu	\$1,231.00	\$1,169.45	\$1,107.90
HDX-**C-MC	1978-87 Monte Carlo	\$1,231.00	\$1,169.45	\$1,107.90
HDX-**C-VET	1963-67 Corvette	\$1,611.00	\$1,530.45	\$1,449.90
HDX-**D-CHG	1968-70 Dodge	\$1,421.00	\$1,349.95	\$1,278.90

VHX SERIES GAUGES

The VHX Series features fully lit needles, backlit faces, and highly visible LCD message centers. A few additional features which you don't normally see are the micro-controlled precision stepper motors, solid state sensors for unparalleled accuracy, and user-customizable display feedback, all supported by an unrivaled limited lifetime warranty which has become the standard for Dakota Digital instrumentation systems. Gauge faces are available in Carbon Fiber or Black Alloy with either blue, red or white backlight options.

** Call for specific applications

starting at

PART #	DESCRIPTION	RETAIL	JOBBER	DEALER
VHX-**C-PU-C-*	1947-87 Chevy Truck	\$756.00	\$718.20	\$680.40
VHX-**F-PU-C-*	1937-70 Ford Truck	\$756.00	\$718.20	\$680.40
VHX-**C-C-*	1937-57 Chevy Car	\$756.00	\$718.20	\$680.40
VHX-**C-CAC-C-*	1967-81 Camaro	\$851.00	\$808.45	\$765.90



1953 FORD TRUCK



1978 MONTE CARLO

MANY OPTIONS AVAILABLE

starting at

PART #	DESCRIPTION	RETAIL	JOBBER	DEALER
VHX-**C-IMP-C-*	1958-70 Impala	\$756.00	\$718.20	\$680.40
VHX-**C-NOV-C-*	1963-76 Nova	\$756.00	\$718.20	\$680.40
VHX-**C-CVL-C-*	1964-72 Chevelle	\$756.00	\$718.20	\$680.40
VHX-**C-MC-C-*	1978-88 Monte Carlo	\$756.00	\$718.20	\$680.40
VHX-**B-REG-C-*	1984-87 Regal	\$756.00	\$718.20	\$680.40



NEW!

#RG5559PUD-2SD

RAINGEAR WIPER SYSTEMS

RainGear wiper system is a modern, high-quality replacement for the old system. It is the only replacement wiper system that is completely hidden, fitting entirely within the airbox in the cowl! This allows you to remove the stock wiper motor. The wiper motor hole in the firewall can be covered up with the cover plate supplied in the kit or you can weld in a patch panel to eliminate the hole entirely. Perfect for Pro Street cars or if you just desire a clean looking firewall. *Note: The RainGear unit cannot be controlled by any General Motors column-mounted wiper switches. You must use the included switch. This is due to the fact that GM switches control the wiper motor via the ground wire and our systems must be controlled by switching the positive wire.*

PART #	DESCRIPTION	RETAIL	JOBBER	DEALER
RG4754PU-2S	1947-54 Chevy Truck, 2 speed, kit	\$445.00	\$423.00	\$400.00
RG4754PU-2SD	1947-54 Chevy Truck, 2 speed w/ delay, kit	\$500.00	\$475.00	\$450.00
RG5354-2S	1953-54 Chevy Car, 2 speed, kit	\$445.00	\$423.00	\$400.00
RG5354-2SD	1953-54 Chevy Car, 2 speed w/ delay, kit	\$500.00	\$475.00	\$450.00
RG5357-2S	1953-57 Corvette, 2 speed, kit	\$500.00	\$475.00	\$450.00
RG5357-2SD	1953-57 Corvette, 2 speed w/ delay, kit	\$550.00	\$522.00	\$495.00
RG5556-2S	1955-56 Chevy, 2 speed, kit	\$445.00	\$423.00	\$400.00
RG5556-2SD	1955-56 Chevy, 2 speed w/ delay, kit	\$500.00	\$465.00	\$430.00
RG5559PU-2S	1955-59 Chevy Pickup, 2 speed, kit	\$350.00	\$332.00	\$315.00
RG5559PUD-2SD	1955-59 Chevy Pickup, 2 speed w/ delay, kit	\$400.00	\$380.00	\$360.00
RG57-2S	1957 Chevy, 2 speed, kit	\$500.00	\$475.00	\$450.00
RG57-2SD	1957 Chevy, 2 speed w/ delay, kit	\$550.00	\$522.00	\$495.00
RG5862-2S	1958-62 Corvette, 2 speed, kit	\$500.00	\$475.00	\$450.00
RG5862-2SD	1958-62 Corvette, 2 speed w/ delay, kit	\$550.00	\$522.00	\$495.00
RG6467-2S	1964-67 Chevelle/Tempest/Cutlass/Skylark, 2 speed, kit	\$500.00	\$475.00	\$450.00
RG6467-2SD	1964-67 Chevelle/Tempest/Cutlass/Skylark, 2 speed w/ delay, kit	\$550.00	\$522.00	\$495.00
RG67-2S	1967 Camaro/Firebird, 2 speed, kit	\$600.00	\$570.00	\$540.00
RG67-2SD	1967 Camaro/Firebird, 2 speed w/ delay, kit	\$650.00	\$617.00	\$585.00
RG68-2S	1968 Camaro/Firebird/Nova, 2 speed, kit	\$600.00	\$570.00	\$540.00
RG68-2SD	1968 Camaro/Firebird/Nova, 2 speed w/ delay, kit	\$650.00	\$617.00	\$585.00
RG6974-2S	1969 Camaro/Firebird, 1969-74 Nova, 2 speed, kit	\$600.00	\$570.00	\$540.00
RG6974-2SD	1969 Camaro/Firebird, 1969-74 Nova, 2 speed w/ delay, kit	\$650.00	\$617.00	\$585.00
RG7078-2S	1970-78 Camaro/Firebird, 2 speed, kit	\$550.00	\$522.00	\$495.00
RG7078-2SD	1970-78 Camaro/Firebird, 2 speed w/ delay, kit	\$600.00	\$570.00	\$540.00
RG7078-2SDP	1970-78 Camaro/Firebird, 2 speed w/ delay & pantograph, kit	\$630.00	\$598.00	\$567.00
RG7078-2SP	1970-78 Camaro/Firebird, 2 speed w/ pantograph, kit	\$580.00	\$551.00	\$522.00
RGF4852PU-2S	1948-52 Ford F-1 P/U, 2 speed, kit	\$430.00	\$408.00	\$387.00
RGF4852PU-2SD	1948-52 Ford F-1 P/U, 2 speed w/ delay, kit	\$480.00	\$456.00	\$432.00
RGF5355PU-2S	1953-55 Ford F-100, 2 speed, kit	\$430.00	\$408.00	\$387.00
RGF5355PU-2SD	1953-55 Ford F-100, 2 speed w/ delay, kit	\$480.00	\$456.00	\$432.00
RGF56PU-2S	1956 Ford Pickup, 2 speed, kit	\$450.00	\$427.00	\$405.00
RGF56PU-2SD	1956 Ford F-100 Pickup, 2 speed w/ delay	\$500.00	\$475.00	\$450.00

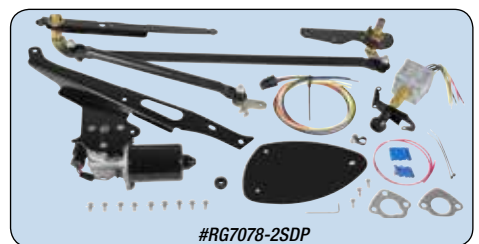
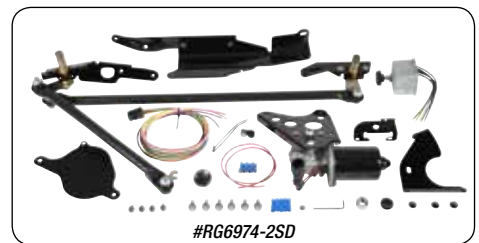
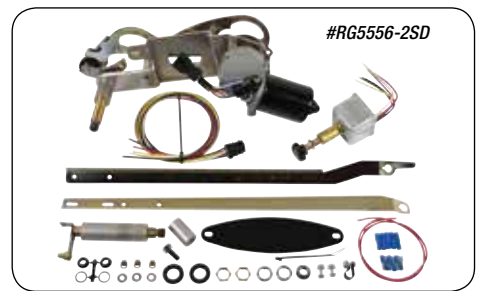

MISCELLANEOUS



HARD TO FIND 1967-72 C10 ALTERNATOR BRACKET SET!

ALTERNATOR BRACKET KIT

Heavy-duty bracket mounts on driver side head and places the alternator up alongside the valve cover. Perfect upgrade when using aftermarket headers. Small block Chevy, short water pump, std. valve cover. Fits a 1967-72 C10 and 1972-78 C3 Corvette (popular with SBC conversions).



#6772ABK

PART #	DESCRIPTION	RETAIL	JOBBER	DEALER
6772ABK	kit	\$89.00	\$79.00	\$62.00



#WK1013



SET OF 4



SET OF 4



#WK1012

RALLY WHEEL DERBY CAPS

Each cap is manufactured in injection molded plastic, then chrome plated for a quality shine and finish. Features cap and ornament in 1-piece construction.

PART #	DESCRIPTION	RETAIL	JOBBER	DEALER
WK1013	Chrome Plastic Tall, ea.	\$20.00	\$19.00	\$18.00
WK1013-4	Chrome Plastic Tall, 4-pc. set	\$72.00	\$68.40	\$68.40
WK1012	Chrome Plastic Tall with Bow Tie, ea.	\$50.00	\$47.50	\$45.00
WK1012-4	Chrome Plastic Tall with Bow Tie, 4-pc. set	\$180.00	\$171.00	\$162.00



#6769WWF

WHEEL WELL WIDENING FENDER KIT

CPP's wide wheel fender kit is a simple, DIY variation of a mini tub kit. They maintain the OE shock mounting position, requires minimal cutting, welding and fabrication in the trunk and back seat mounts and work with the original interior and upholstery.

PART #	DESCRIPTION	RETAIL	JOBBER	DEALER
6769WWF	1967-69 Camaro, 2" wide, kit	\$129.00	\$119.00	\$89.00
7081WWF	1970-81 Camaro, 1" wide, kit	\$119.00	\$109.00	\$79.00



#7081WWF INSTALLED ON 1972 CAMARO

CPP WIRING KITS

Our CPP wiring kits are complete harnesses from headlight to tail light. All wires are individually marked on what component they go to every couple inches taking the guess work out of what wires go where. All have a pre-assembled fuse block that can mount to the firewall or any part of the car basically allowing for a custom installation. We offer basic kits with 12 circuits to fully expandable 22 circuit kits. This allows installation in anything from a basic street rod to a setup that requires many options like air conditioning, heat, brake light, emergency flashers, wipers, tail lights, etc.

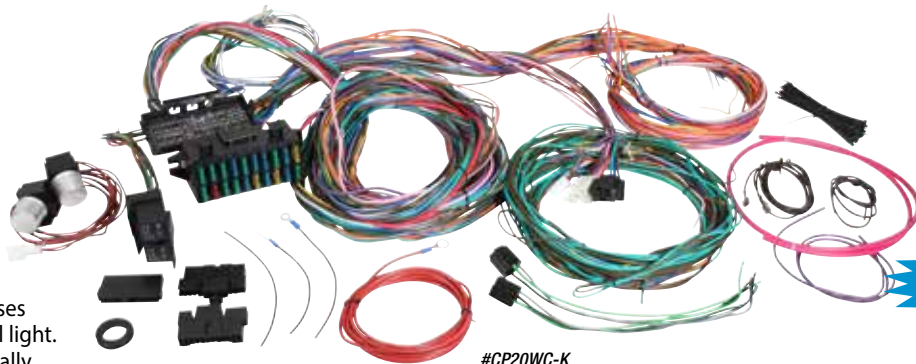

#CP20WC-K

ALL WIRES INDIVIDUALLY MARKED



PART #	DESCRIPTION	RETAIL	JOBBER	DEALER
CP12WC-K	12 Circuit, GM	\$189.00	\$168.00	\$147.00
CP20WC-K	20 Circuit, GM	\$189.00	\$168.00	\$147.00

PART #	DESCRIPTION	RETAIL	JOBBER	DEALER
CP22WC-K	22 Circuit, GM	\$199.00	\$183.00	\$166.00



NEW!

ENGINE FIREWALL INSTALLATION

#HRD-556FW



#HRD-57W



1955-57 ENGINE FIREWALL

Clean up the engine compartment on your Tri-Five! Features a 4" recess that works great with any engine and fabricated from 16ga steel. Requires basic fabrication and welding skills to install.

PART #	DESCRIPTION	RETAIL	JOBBER	DEALER
HRD-556FW	1955-56 Chevy Fullsize/Tri-Five	\$445.00	\$422.00	\$399.00
HRD-57FW	1957 Chevy Fullsize/Tri-Five	\$445.00	\$422.00	\$399.00



RACER (POLISHED)



CRUISER



STREETER

**CPP
NOW
CARRIES...**

*American
Legend*
WHEELS

Rugged, durable, pressure cast, 1-piece construction and detailed finish makes these an excellent value! Precision engineered and manufactured to meet USA SAE and Australian standards.

**CONTACT
US TODAY FOR
PRICING!**



LEGEND



LEGEND SPRINTER



LEGEND RACER

DEALER TEAM SERVICES



DEDICATED MAILBOX

dealer@classicperform.com

DIRECT DEALER TEAM EXTENSION

1-800-522-5004 - ext. 608

Product and Tech Support:

Aaron StrietzelExt. 125
aaron@classicperform.com

Javier Nuñez.....Ext. 130
javier@classicperform.com

Jeff Norton.....Ext. 118
jeff@classicperform.com

Jason Oberhelman.....Ext. 136
jasono@classicperform.com

Sales, Stock Check, Billing, Order Entry:

Yusely Nuñez Ext. 127
yusely@classicperform.com

Jennifer Matthews..... Ext. 120
jenniferi@classicperform.com

Cathy White Ext. 106
cathy@classicperform.com

Sales Manager:

James FergusonExt. 141
jamesf@classicperform.com

Marketing:

Cathy WhiteExt. 106
cathy@classicperform.com

Vice President of Operations:

Victor Zendejas.....Ext. 113
victorz@classicperform.com



TUBULAR CONTROL ARM DISPLAY STAND*

BOOSTER DISPLAY STAND*

CUSTOM BILLET ALUMINUM TIE ROD SLEEVES DISPLAY STAND*



CPP AUTHORIZED DEALER BANNER*



WHEEL KIT DISPLAY STAND*

CP50000 GEAR BOX DISPLAY STAND*

CPP offers a wide range of marketing materials and displays stands to help you succeed.
**Parts displayed on stands may be non-functional.*

BE A PART OF OUR ONLINE MEDIA

#CLASSICPERFORM



BUSINESS HOURS:
 8:00am to 5:00pm Monday - Friday
 8:00am to 1:30pm Saturday
 Closed Sunday

Classic Performance Products, Inc.

Prices subject to change without notice. Some images may be representative of product. Please note that kits and prices may vary between certain applications.