

*Classic Performance Products, Inc.*

# Disc Brake & Power Steering

## Installation and Technical Guide

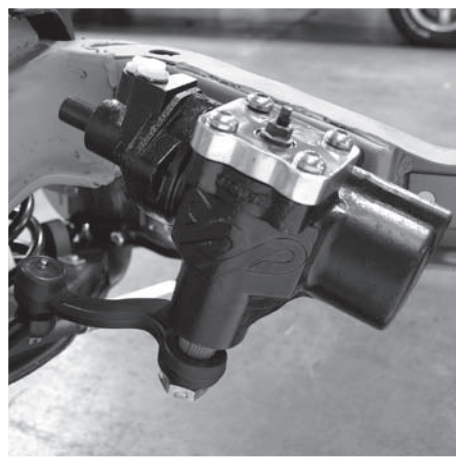
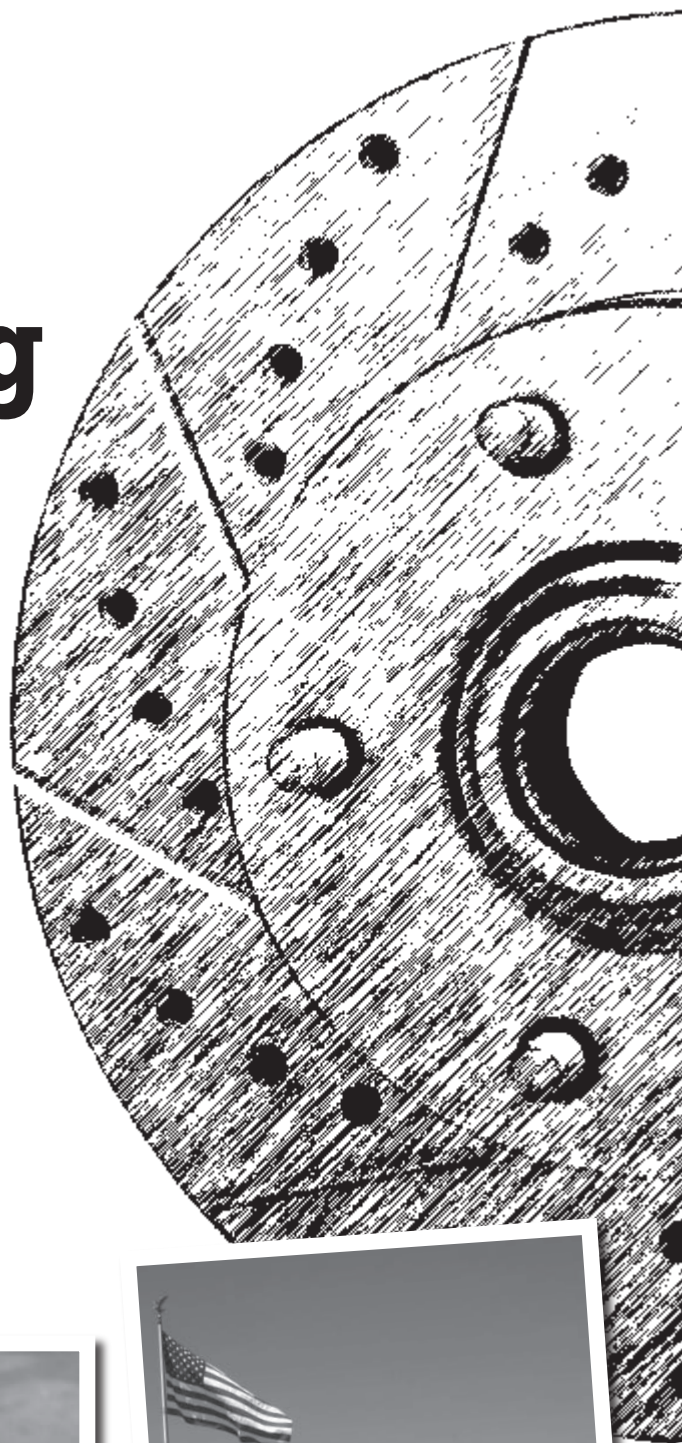

## Introduction and Tips

*Read these instructions carefully and completely before installing your kit! The steps within this guide should be followed in the order in which it is written. Here are a few guide lines to help ensure a safe brake system:*

*Follow the steps outlined in this guide to ensure that you will easily pinpoint any trouble spots in your brakes while installing and assembling the system. This guide was created to help make your brake install as trouble free as possible. Follow these instructions and we are certain you will have a pleasurable experience with your upgrade.*

- Add only new brake fluid. Contaminated fluid can cause damage to the sensitive hydraulic brake components, corrode components, and increases the chance of system failure. Even unused fluid that was opened at an earlier time should not be used. Brake fluid absorbs moisture from the air. This moisture lowers the boiling point of the fluid. DOT 4 & 5 brake fluid has a higher boiling point than DOT 3 but a shorter service life. DOT 3 fluid should be flushed every 2 years, while Dot 4 & 5 brake fluid should be flushed every year to ensure a safe working system.
- Cleanliness is very important. In order to keep the system clean and safe make sure you clean the fittings and surrounding area before opening any part of the brake system.
- Do not mix silicone based brake fluid with conventional brake fluid. DOT rated silicone brake fluid is safe to use, but can not be completely removed from the system once it has been added. Silicone fluid will feel more “spongy” than conventional fluid. Silicone will cause the seals to swell differently than conventional fluid and lead to a shorter seal life. Silicone fluid will not absorb moisture. If there is any moisture in the brake system it will boil at 212°; this means the boiling point for the entire system is now 212°.
- Be sure to check for a minimum of 18" of vacuum prior to installing a vacuum booster. Engines with “big” performance camshafts typically do not have enough vacuum. If you do not have enough vacuum ask us about our electric vacuum pump.
- If the booster is mounted lower than the intake manifold do not eliminate any loops from the vacuum lines. These loops act as moisture and vapor traps. Check the vacuum lines for gas odor or the presence of moisture. Gas fumes can deteriorate the internal rubber components of the booster.
- Do not use petroleum-based solvents to clean brake components. They will damage the rubber seals in the brake system. Use only cleaning fluids specifically designed for brakes. They will not leave a residue when they dry.
- Do not use compressed air to dry brake components, even filtered air may contain moisture or traces of oil.
- Check for cracked, leaking, or swollen lines. These are dangerous and must be replaced.
- Do not attempt to drive the vehicle until a firm brake pedal is established.

*Classic Performance Products, Inc.*

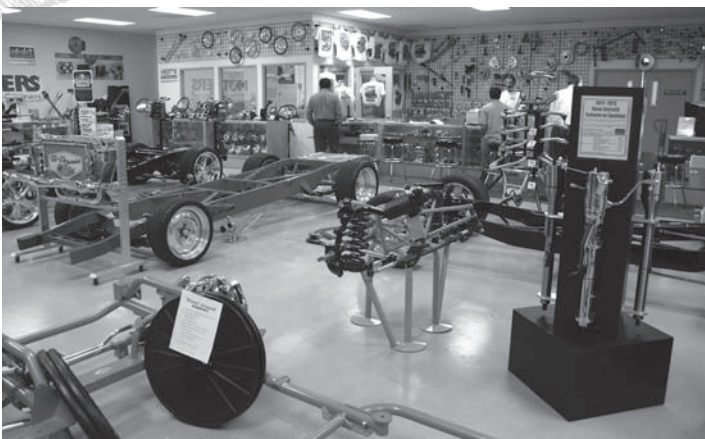

*If you are in our area, stop by and visit. Our huge showroom features all of our latest products and accessories.*

**CPP BRAKE & POWER STEERING INSTALLATION GUIDE**

@ 2008 CLASSIC PERFORMANCE PRODUCTS, INC.

NO COPIES OR REPRODUCTIONS IN ALL OR IN PART OF THIS DOCUMENT MAY BE MADE WITHOUT WRITTEN CONSENT OF CPP EXCEPT IN THE EXPRESS USE FOR INSTALLING OR TROUBLESHOOTING CPP SUPPLIED PRODUCT. ALL RIGHTS RESERVED. LAST REVISED 5-08

## Table of Contents

Introduction and Tips.....	pg. 2
Why Change to Disc Brakes?.....	pg. 3
Understanding the Valves.....	pg. 4
Using the Right Master Cylinder.....	pg. 5
Bolting the Parts Together.....	pg. 6
Pedal Assembly.....	pg. 6
Pedal Rod Adjustment.....	pg. 6
Master Cylinder Bore Depth.....	pg. 7
Mounting the Caliper.....	pg. 7
Routing the Hard Lines.....	pg. 7
Connecting the Hoses.....	pg. 8
Adjusting the Parking Brake.....	pg. 8
Bleeding the System.....	pg. 9
Diagnosing Brake Problems.....	pg. 11
Trouble Shooting the System.....	pg. 12-13
 Power Steering Guide	
Power Steering Fluid.....	pg. 13
Vibrations in Steering Wheel & Column.....	pg. 13
Pressure Reduction.....	pg. 14
Remote Reservoir Systems.....	pg. 14
Connecting the Steering Shafts.....	pg. 14
Fasteners.....	pg. 15
New vs. Used vs. Rebuilt.....	pg. 15
Getting it Up and Running.....	pg. 15
Speaking of the Column.....	pg. 15
V-Belt Systems.....	pg. 15
Serpentine Systems.....	pg. 15
 Common Fitting Sizes.....	
Common Torque Specs.....	pg. 16
Rack & Pinion Pump Diagram.....	pg. 16
Steering Boxes & Racks Spline Sizes.....	pg. 17
Steering Column Spline Sizes.....	pg. 17
Determining Spline Size.....	pg. 17
U-Joint Phasing.....	pg. 17
General Torque Specifications.....	pg. 17

## WHY CHANGE TO DISC BRAKES?

### ADVANTAGE #1

Disc brakes offer a significant advantage over drum brakes in a number of areas, the most important being safety.

### ADVANTAGE #2

Disc brakes resist brake fade better than drums brakes do. Heat causes the disc to grow wider between the brake pads reducing the pedal travel before the pads start to engage the rotors. Drums expand farther away from the shoes increasing the pedal travel before the shoes start to engage the drums.

### ADVANTAGE #3

Disc brakes work better than drums when wet. When disc brakes become wet, the large majority of the water is spun off the disc. Then more water is wiped off by the brake pad. Very little water will remain on the rotor, and is quickly removed as the brake pressure is increased. In a drum brake set up, water can become trapped inside the drum and act as a lubricant between the drum and shoes.

### ADVANTAGE #4

Disc brakes are much safer during a stop. Drum brakes have a tendency to pull one way or the other. This pull varies as shoes wear, return spring fatigue from age, the pivot mechanism wear, lubrication dries out, etc.

### ADVANTAGE #5

Ease of serviceability. Disc brakes are much easier to service than drum brakes.

*Still have questions? Give us a call, and a knowledgeable CPP customer service representative will be happy to assist you.*

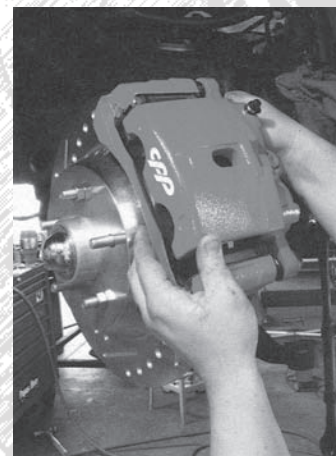

# UNDERSTANDING THE VALVES

## RESIDUAL VALVES

When setting up the brake system make sure that the right valves are used. If the master cylinder reservoir is located lower than the wheel cylinders or calipers then you should have residual pressure valves. Use a 2psi valve for disk brake calipers and 10psi valve for drum brake wheel cylinders. The valve will maintain 2 or 10psi between the caliper/wheel cylinder and the valve. That is enough pressure to keep the brake fluid from flowing back from the wheels and leaking past the reservoir vent and on to the ground. The second function of the residual pressure is that there is a slight preload on the brakes keeping them "at the ready."

## COMBINATION VALVES

The combination valve is several valves in one. There is a brake light warning switch and isolation valve, a metering valve for the front brakes, and a proportioning valve for the rear brakes.

## ISOLATION VALVES

The brake light warning switch also known as a pressure differential switch is part of the isolation valve. The isolation valve is controlled by the front and rear incoming brake pressure. The valve has incoming brake pressure acting on each side of a piston. If the pressure on one side of the piston is more than the other side, the piston will start moving toward the lower pressure. At a predetermined point of piston movement the brake light warning switch is triggered. If the pressure difference continues the piston will move far enough to completely stop fluid flow to the side with the lower pressure. At this point the piston will not return to center until the valve is disassembled and reset. Let's say that one of the front brake hoses were to burst. The lack of front brake pressure would have caused the warning light to come on, and the isolation valve would stop the fluid flow to the front brakes. At the same time the rear brakes are still working, and there is only a minimal loss of brake fluid.

## METERING VALVES

The metering valve causes a slight delay in the front brakes. The valve stops fluid from moving until it is above a preset pressure (75 to 150psi) then the valve opens and the fluid flow is normal. The metering valve's purpose is to have the rear drum brakes build enough pressure to overcome the return springs allowing the rear shoes to engage the rear drums at the same time the front brake calipers engage the front disks. If the metering valve is used with rear disc instead of rear drums, the valve function will be the same, however the rear brakes will engage before the front. This has no negative effects; the rear brake pressure is not high enough to cause any problems, and will add slightly more stability under light braking.

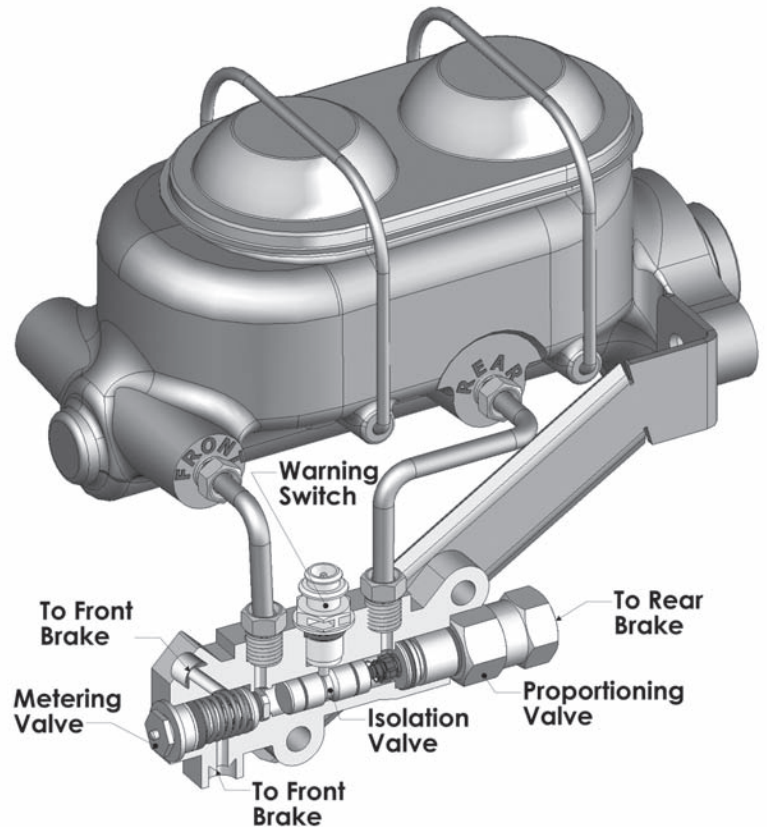

## PROPORTIONING VALVES

The front to rear brake balance is partly controlled by the proportioning valve. The proportioning valve has two functions. First it will reduce the rear brake pressure that exits the valve. Second, it limits the maximum pressure. If the rear brake pressure coming into the valve is below a preset pressure, typically 500psi, there is no difference in the pressure exiting the valve. The pressure required for the valve to start reducing pressure is known as the split or knee point. After the split point the pressure leaving the valve will be less than the pressure entering the valve. When the output pressure has reached a preset maximum point the valve will close and prevent the rear brakes from getting any more pressure. Let's look at an example where the brakes are applied in a hard stop. The pressure will rise front and rear equally to about 500psi after that the rear pressure will rise at about half the rate the front does. With 1000psi at the front brakes there will be about 750psi to the rear brakes. (The first 500psi is equal; increasing the front another 500psi will increase the rear 250psi.) Once the rear brakes reach their maximum pressure the front can continue to rise without the rear rising. Limiting the rear maximum pressure prevents the rear drums from being damaged by too much pressure and helps control rear wheel lock up. The proportioning valves work together with the isolation valve. If the isolation valve cycles to prevent the front brakes from getting pressure, the proportioning and limiting functions will be bypassed. If the front brakes have failed there would be no need to balance the braking forces front to rear.

# USING THE RIGHT MASTER CYLINDER

Master cylinders come in a variety of sizes, capacities, mounting configurations, plumbing configurations, and some have valves built into them.

## RESERVOIR SIZE

The master cylinder reservoir should always hold enough fluid to allow the brake pads to completely wear away without the risk of running out of fluid. As a disc brake pad wears the caliper piston will extend out of its bore. As the caliper piston extends, the master cylinder fluid level will drop in order to fill the caliper bore with brake fluid. If the reservoir is too small there is a possibility that the master cylinder can run out of fluid and the brakes will fail.

## MOUNTING CONFIGURATION

There are two common mounting configurations. One is known as deep bore and the other is known as shallow bore. This refers to the way the pushrod engages the master cylinder. A deep bore master cylinder will have the pushrod extend about 1-1/2 inch into the master cylinder. A shallow bore master cylinder will have a push rod extend about 1/4 inch into the master cylinder. All manual brake applications should be a deep bore set up. In a deep bore setup the pushrod will go about two inches into the master cylinder. This deep engagement ensures that the pushrod can not accidentally fall out of the master cylinder. Some power booster applications require a deep bore master cylinder, however most use a shallow bore master cylinder. The relation of the push rod to the master cylinder is very important. If there is too much clearance between them the brake pedal will be low and may go all the way to the floor before the brakes start to function. If there is not enough clearance, the master cylinder may become "preloaded" by the push rod. If the master cylinder has preload, the brakes will drag and get hot; when this happens to a disc brake the brakes can sometimes lockup. It may become impossible to move the vehicle until the brakes have cooled down, or the bleed screws are opened to relieve the hydraulic pressure.

## PLUMBING CONFIGURATIONS

Most vehicles built before 1967 were equipped with a single circuit master cylinder. These master cylinders are also known as a single system. If any portion of a single system were to fail there will be no brakes. A single circuit master cylinder can be easily identified by the single tube plumbed into the master cylinder. Every vehicle made from 1967 on will have been equipped with a dual circuit master cylinder. These have two independent hydraulic systems working inside one master cylinder. If one portion of the system failed the second system will continue to function. These dual systems will have at least two tubes plumbed into the master cylinder. Some of these dual circuit master cylinders will have provisions to plumb four tubes into

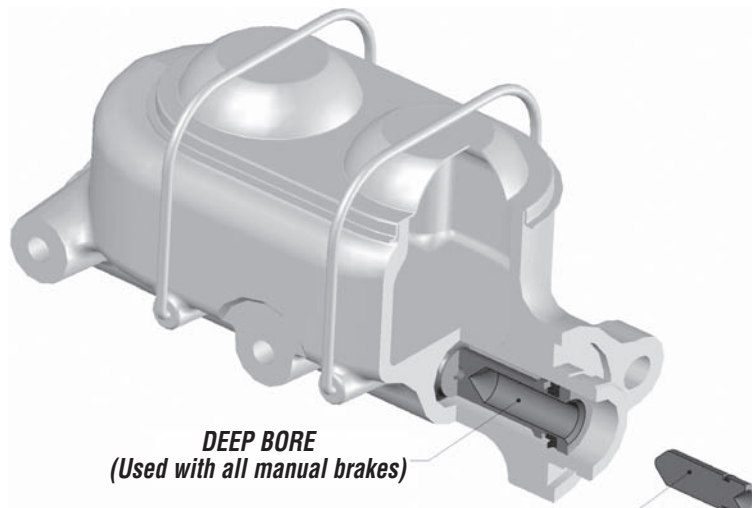

**DEEP BORE**  
(Used with all manual brakes)

**BORE ADAPTER**  
(Used with some power brakes)

them. This can be helpful when using the master cylinder in a custom application where there is not enough space on one side of the master cylinder to plumb the tubes.

## MASTER CYLINDERS WITH BUILT-IN VALVES

Some master cylinders have valves built in. These valves work similar to the valves that would be plumbed externally. Internal valves have fewer connections and therefore fewer places for a potential leak. They are also simply the plumbing, and help make the system look better.

# BOLTING THE PARTS TOGETHER

The entire brake system should be dry fitted and adjusted before any brake fluid is added, or the system is bled. This is done so that you can remove part of the system in order to make an adjustment and not lose any fluid or have to re-bleed the brakes.

## PEDAL ASSEMBLY

Something that many people are not aware of when upgrading their system is the brake pedal adjustment. Improper pedal adjustment can do the following:

- Preload the booster causing brakes to drag and eventually lock up.
- Damage the booster's internal components by actuating at an improper angle.

Many vehicles have a second hole on the pedal assembly that was originally intended for power brake applications. The required hole is generally 1" to 1-1/2" lower than the original manual brake hole. If there is no second hole, you may need to drill the hole in the pedal

arm to properly align the push rod. The easiest way to determine the perfect location for this hole is to find the center of the push rod's vertical travel to ensure that its actuation is as inline with the booster as possible.

1. Gently lift the end of the pushrod until it stops and noting the location where the clevis on the pushrod locates on the pedal arm. You can mark this location.
2. Then gently push the pushrod down until it stops. Mark this location as well.
3. The correct location for the hole is in the middle between the two marks on the pedal arm. Mark and drill the new hole in the center of the pedal arm. Attach the pushrod to the pedal arm.

### PEDAL ROD ADJUSTMENT

Check free play in the pedal by applying pressure to the pedal with your hand and noting how far the pedal travels before resistance is felt. It should be approximately 1/4", adjust the rod as needed. This free play allows the master cylinder piston to return to the "at-rest" position and prevents preloading the system. Too much free play will drop the pedal too far before applying brake pressure and the pedal may even hit the floor before applying full braking force to the system. Note: Free play is also dependent upon proper adjustment of the booster pushrod. See "Adjusting the Booster Pushrod" below.

## MASTER CYLINDER BORE DEPTH

*Warning: All manual brake applications MUST use a deep bore master cylinder.* This will prevent the push rod from being able to fall out of the master cylinder. A deep bore master cylinder will have the pushrod extend about 1-1/2 inch into the master cylinder. A shallow bore master cylinder will have a push rod extend about 1/4 inch into the master cylinder. CPP has a bore adapter that will convert a standard GM deep bore into a shallow bore.

The booster push rod and master cylinder need to be matched to each other. Most boosters are made to work with a shallow bore master cylinder; however some boosters require a deep bore master cylinder. Warning; never preload a master cylinder, the brakes will drag and overheat!

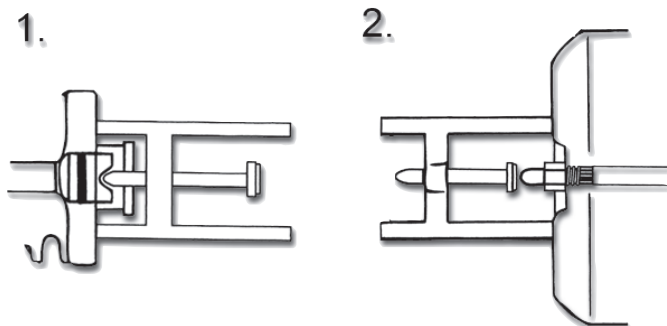

### ADJUSTING THE BOOSTER PUSHROD

The pushrod that actuates the master cylinder must be properly adjusted. There should be a slight clearance between the booster pushrod and master cylinder. Interference between the pushrod and master cylinder will preload the master cylinder. When the master cylinder is preloaded it will not release the hydraulic pressure causing the brakes to drag and heat up. As disc brakes heat up they expand between the pads and can eventually lock the brakes. Too much clearance will cause excessive free play in the pedal.

To make 100% certain of a properly adjusted booster pushrod for your master, we offer a master cylinder depth gauge (#CP2003) the following illustration demonstrates how to use this tool. First measure the distance the booster pushrod extends past the mounting surface of the booster. Then measure the depth of the master cylinder piston with the other end of the tool. Adjust the pushrod as needed.

## MOUNTING THE CALIPER

When mounting the brake calipers ensure that the bleed screws are positioned above the piston bore. If the bleed screws can not be positioned high enough, it may be necessary to unbolt the caliper from its mount and temporarily reposition it while the caliper is being bled.

Check that the caliper is square to the rotor. If the caliper is misaligned, it will cause the brake pedal to have a long stroke, feel "soft", and may allow to the pedal to travel to the floor without stopping the vehicle. Depending on the type of caliper and mounting bracket it may be necessary to shim or "tweak" (lightly bend) the mounting bracket. Some caliper installations may require the caliper be shimmed on its mount. Always follow the manufactures instructions for mounting the calipers.

### ROUTING THE HARD LINES

There are several guidelines you need to follow when routing the hard lines (brake tubing) thru the vehicle.

Minimize the amount of heat the lines are exposed to. Always keep the lines as far from as the exhaust as possible.

Secure the lines so that they can not chafe or rub against other objects.

Only use brake line tubing made specifically for brake lines. Tubing made from other materials may crack, split, or burst over time from repetitive use.

Always connect the hard lines with a flared fitting. Warning: never use a compression fitting, they can fail with the high pressures in a brake system.

Never use a line with a kink. A kinked or crushed line is more likely to break, and can hold hydraulic pressure between the caliper/wheel cylinder and the kink, or prevent pressure from reaching the caliper/wheel cylinder.

### CONNECTING THE HOSES

Never install a hose with a twist in it. The length of the hose should be adequate to allow full suspension movement and steering movement without pulling the hose tight. The hoses should be routed in a way to prevent them from rubbing against any other objects, especially the tire and wheel. If the hoses show signs of cracking, swelling, or leaking they should be replaced with new hoses. If the brake fluid is dirty and you are installing new components, you should replace the hoses before you bleed or flush the brake fluid. The hoses will have the smallest restriction that the brake fluid must move thru. If there are any loose objects in the brake fluid such as rust, they can collect and clog the brake hose.

### ADJUSTING THE PARKING BRAKE

Adjusting the parking brake is a critical step that many people miss when installing rear disc brakes. Our rear disc brake calipers are equipped with an integral self adjusting parking brake. Regular use of the parking will compensate for pad wear. If you do not use your parking brake during normal operation you can expect the pads to wear and develop more of a gap between the rotor and the pads. This will make the pedal go lower to the floor. The parking brakes should be adjusted before the brakes are bled. Failure to adjust the parking brake can result in no brakes, dragging brakes, over heating brakes, and premature brake wear. Lincoln style calipers simply apply the parking brake several times until the parking brake can stop the car from rolling. If using the Cadillac style caliper follow this procedure:

1. Tighten the rotor against the axle flange.
2. Install the caliper in its mounting bracket.
3. Remove the parking brake return spring.
4. Cycle the parking brake several times. Do this by moving the lever in the same direction the cable would pull it. This motion would compress the return spring if were still installed. Some caliper assemblies may self adjust by cycling the lever in this way, other may not it simply depends on how much internal friction the parking brake assembly has compared to the friction caused by the piston seal.
5. When the parking brake is adjusted correctly, the lever will only move 1/16" to 1/8" from the stop that limits the levers movement to the fully released position (see illustration in next column). If the parking brake is correctly adjusted, reinstall the return spring,

#### Parking Brake Engaged:

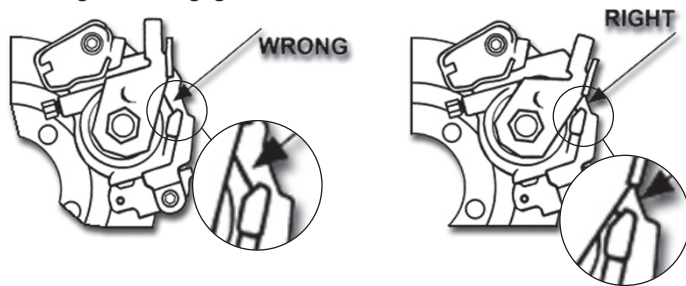

and finish the installation. If the lever moves more than 1/8", continue with the adjustment procedure.

6. Remove the nut, lever, seal and nylon washer from the adjusting screw that secures the parking lever to the caliper assembly. Place them in a clean location.
7. Temporarily attach the parking brake lever and position the lever against the stop. Without rotating the shaft the lever is attached to, remove the lever and mark the position of one of the points on the hexagon shaft.
8. Loosely install the nut back onto the lever shaft. Using a 9/16" open end wrench turn the shaft in the direction opposite to the direction the cable pulls the lever. As you turn the lever, the shaft will move into the caliper housing until the wrench is snug against the nut and the caliper; as you continue to rotate the shaft, the internal ratchet mechanism within the caliper will begin to adjust. (You should be able to feel the resistance increase slightly once the ratchet mechanism begins to adjust.) Once you have made an adjustment to the mechanism, turn the shaft in the direction to activate the parking brake. Using the wrench turn the shaft until the parking brake is applied. Check to see if the mark you made lines up with one of the points on the hexagon shaft. If not, continue to make adjustments until the mark lines up with of the points on the hexagon shaft. Remove the wrench and nut from the shaft. Reinstall the lever in the correct position to work with the spring and cable. Do not install the nylon washer or the seal at this time. Further adjustment may be needed. Using the lever, activate the parking brake. Check to see if the parking brake is now adjusted. The lever should not move more than 1/8 inch from the stop. If the parking brake is not adjusted correctly, make another adjustment as explained in this step.
9. Once the brake is adjusted, reinstall the seal and nylon washer between the caliper body and the parking brake lever. Tighten the lever retaining nut, and reinstall the parking brake return spring.

### BLEEDING THE SYSTEM

Do not attempt to bleed the brakes until after the complete brake system as been dry fitted.

## Brake & Power Steering Installation and Technical Guide

If you are replacing the master cylinder, or the brake reservoir has been emptied you will need to bench bleed the master cylinder.

### **BENCH BLEEDING THE MASTER CYLINDER**

The master cylinder can be bench bled by two different methods. The conventional method requires a tool like a screwdriver be used to cycle the master cylinder by hand. This method causes a small amount of foam in the master cylinder. The other method is to use a syringe to push fluid thru the master cylinder. This method will not cause the fluid to foam.

**The conventional method:** Mount, hold, clamp or secure the master cylinder in a level position. A bench vise is a good way to keep the master cylinder level. Fill the master cylinder reservoir/s with brake fluid. If you have a master cylinder bleed kit, install the fittings into the master cylinder, connect the hoses to the fittings, and put the other end of the hose into the master cylinder reservoir. If you do not have a master cylinder bleed kit you will want to have some sort of container under the master cylinder to catch the fluid that comes out of the master cylinder ports. With your screwdriver like tool compress the master cylinder piston until it reaches the bottom of its travel. Release the pistons so that it will return to the "at rest" position. Continue to cycle the master cylinder until no more air comes out of the master cylinder ports.

**The syringe method:** Mount, hold, clamp or secure the master cylinder in a level position. A bench vise is a good way to keep the master cylinder level. Fill the master cylinder reservoir/s with brake fluid. If you have a master cylinder bleed kit, install the fittings into the master cylinder, connect the hoses to the fittings, and put the other end of the hose into the master cylinder reservoir. If you do not have a master cylinder bleed kit you will want to have some sort of container under the master cylinder to catch the fluid that comes out of the master cylinder ports. Using the syringe, inject brake fluid directly into the larger of the two openings in the bottom of each master cylinder reservoir. The larger hole is closest to the master cylinder mounting flange. It is known as the take up port. As fluid enters the take up port, it will fill the take up portion of the master cylinder and then begin to fill the rest of the master cylinder. Continue using the syringe to inject fluid into the master cylinder until no more air comes out of the master cylinder ports. You will need to do this for each circuit in the master cylinder. There is a take up port for each circuit.

Immediately after bench bleeding the master cylinder reinstall it back onto the car and connect the brake lines. The more quickly this it is reinstalled the less chance of getting air back into the master cylinder.

### **BLEEDING THE BRAKES**

The purpose for bleeding the brakes is to remove all of the air from within the brake system. Any amount of air trapped in the brake system is dangerous. It will cause the brake pedal to feel spongy, soft, low, and may completely prevent the brakes from working. You will

need to push the air out of the system by moving a large amount of fluid thru the system as quickly as possible. An air bubble will rise up to the highest point it can. A bubble will never move down on its own, it will need to be forced down with a flow of brake fluid. If you attempt to "gravity bleed" the system you will never remove all of the air. In some applications you may need to use a pressure bleeder in order to remove all of the air. A typical pressure bleeder can move several gallons of fluid non stop in under 1 minute.

*Example; you have a long run of brake line that runs up and down. As you pump the pedal you move enough fluid to push the air bubble almost to the bottom of the run. As you release the pedal, gravity pulls the fluid to the bottom of the run while the bubble moves back to the top. The bubble will have a "yo-yo" action where it goes down and up but never gets removed from the brake line no matter how many times you pump the pedal.*

Top off the master cylinder reservoir with new brake fluid before you begin to bleed the brake system. Check the reservoir often. As you bleed the brakes, count how many pumps you have done and check the brake fluid level. You should be able to get an idea of how often to check the fluid level. As a general rule you can get 10-15 pumps from the rear circuit before the brake fluid becomes low and 7-12 pumps in the front circuit. If you allow the master cylinder to draw air into the master cylinder bore, or run the master cylinder out of fluid you will need to bench bleed the master cylinder again. To avoid spilling brake fluid keep the lid on the master cylinder as you pump the brakes. When the brake pedal is released the brake fluid will flow back into the reservoir and create a small fountain than can splash and spill over the top of the master cylinder.

Begin at the caliper/wheel cylinder that is farthest from the master cylinder. This will minimize the chance of cycling the isolation valve. As you bleed each caliper/wheel cylinder a small amount of brake fluid will be expelled out of the bleed screw. It is recommended that you use a small piece of clear hose attached to the bleed screw to direct this used brake fluid into a container to prevent making a mess with the brake fluid. You can watch the fluid coming out of the hose and know when the air is removed.

Have an assistant apply a moderate amount of pressure to the brake pedal. Open the bleed screw and allow the air and fluid to be vented from the brake system. Your assistant should press the brake pedal to the floor in a smooth relaxed motion. Do not have the assistant hold the pedal on the floor before the bleed screw is opened. If the brake pedal is held against the floor then there maybe several thousand psi of hydraulic pressure behind the bleed screw; this is dangerous. Opening the bleed screw with that much pressure could injure you or cause damage to your vehicle. Close the bleed screw before your assistant allows the brake pedal to come back up. Continue bleeding the system until there are no signs of air coming out of the bleed screw. Move to the wheel that is the next farthest distance from the



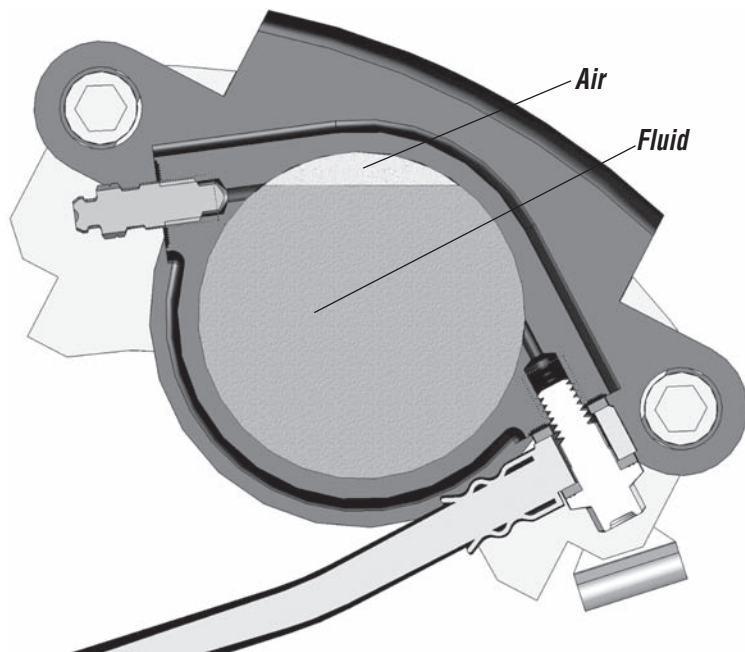

master cylinder. Note; If the bleed screw port does not intersect the caliper bore at its highest point it may be necessary to temporarily reposition the caliper so that the bleed screw port is at the highest part of the caliper bore.

After all of the calipers/ wheel cylinders are bled you should be finished. If the master cylinder mounts so that the front is higher than the back it is possible to get an air bubble trapped inside master cylinder bore. No amount of bleeding will remove this bubble. It is possible to create a back flow that will expel the last bubble trapped within the master cylinder bore. Simply unbolt the master cylinder from the booster, point the master cylinder slightly nose down. For front disc brakes use a small pry bar to pry the inner pad away from the brake disc. This will compress the caliper piston back into the caliper bore and move a large amount of brake fluid from the caliper bore back into the master cylinder reservoir and push that last bubble out of the master cylinder bore and into the reservoir. On rear disc brakes with a parking brake a similar effect can be created by simply applying and releasing the parking brake several time. With drum brakes use a tool like a screwdriver to actuate the master cylinder. As the return springs pull the brake shoes back, the wheel cylinders will compress and push the brake fluid back into the reservoir. Reattach the master cylinder to the booster. On disc brake vehicles you will need to cycle the brake pedal several times to extend the caliper piston out of its bore, and bring the pads back into contact with the disc.

Top off the master cylinder with brake fluid. Install the master cylinder lid. Check that the brakes are working before you attempt to drive vehicle.

### **DIAGNOSING BRAKE PROBLEMS**

Before you attempt to diagnose a brake problem you must have already bled the brakes.

#### **Start with a simple isolation:**

Use clamps or locking pliers to carefully pinch the rubber brake hoses closed. This will check the brake system between the brake pedal and the rubber hoses. Step on the pedal after the hoses are pinched closed. If the brake pedal feels low or soft then the master cylinder is bad, or there is air in the brake system someplace between the clamp up to and including the master cylinder. If the pedal feels good then release the clamps one hose at a time and step on the pedal. This will add only one brake caliper at a time to the brake system. Do this for each hose. Try to identify which hose made the brake feel the worse when the clamp was removed.

Starting at the caliper that made the biggest difference with the simple isolation, carefully inspect the hose for swelling, and the caliper for excess movement. If the caliper has a built in parking brake check that the parking brake is adjusted. A misadjusted parking brake will make the brake pedal feel low and soft. Have someone repeatedly step on the brake pedal. Watch the caliper to see if it is moving or flexing. Also watch the pads to if they are compressing. Some pads are made softer than others and it is not uncommon to see them compress as the brake is applied. If they compress too far it can become a problem. If the caliper is flexing then you will want to switch to a more rigid caliper. If the caliper is twisting or moving on the brackets then the caliper is not aligned with the rotor. Unbolt the caliper from the mounting brackets, leave the caliper on the rotor and step on the brake pedal. This will help to identify whether or not the caliper mounting bracket is not square with the rotor. There will always be some slight misalignment between the caliper and the rotor due to manufacturing tolerances. The brakes will there best when the calipers are aligned with the rotor. If the caliper is not moving, and the parking brake is adjusted there may be air trapped in the caliper.

If there was no one particularly large change when the clamps were released, then all of the brakes may be slightly affected, and the sum of all of them is more than the master cylinder can handle.

Another common problem is brake fade. When the brakes fade they simply lose stopping power. Brake fade occurs when the brake rotor and pad become too hot. The actual temperature that a brake can withstand depends on several factors; the type of friction material, the amount of carbon in the brake disc, the surface of the disc, etc. A brake works by converting movement (the rotation of the disc/drum) into heat. The brake should be large enough to absorb the heat generated in a long hard stop without getting too hot. Then the brake cooling takes effect to cool the brake between stops. If the brake is too light to absorb the heat from a single stop then the brake will fade in the first stop. If the cooling is insufficient then the brake will over heat in subsequent stops, or during a long decent.

## Brake Troubleshooting Chart

SYMPTOM	CAUSE	SOLUTION
<b>Not Enough Brake</b>	Overheated Brake/Brake Fade	Improve the brake cooling Use a slotted and drilled rotor Use a higher temperature brake pad Use a larger brake rotor Use a larger caliper and pad
<b>Soft, Spongy, Low or No Pedal</b>	Air in lines/aerated fluid	Bleed brake system Flush the brake fluid
	Parking brake out of adjustment	Adjust the parking brake
	Incorrect pedal ratio	Change pedal ratio
	Master cylinder bore size too small	Use a larger bore master cylinder
	Bad flexible brake hoses	Replace the brake hoses
	Booster pushrod out of adjustment	Adjust the booster push rod
	Caliper misaligned to rotor	Straighten caliper mounting bracket Shim the caliper mounting bracket Adjust wheel bearings Replace wheel bearings
	Brake pad kick back	Adjust wheel bearings Replace wheel bearings Repair loose axle C-clip (rear disc only) Adjust the parking brake
	Leaking caliper	Replace the caliper
	Bad master cylinder	Replace the master cylinder
	Drum shoes out of adjustment	Adjust the shoes
	Drum and shoe have different arch	Replace drums Replace shoes
	Oversized wheel cylinder	Use a smaller wheel cylinder Use a larger master cylinder
<b>Vacuum Booster not Working</b>	Not enough engine vacuum	Add a vacuum pump
	Broken or blocked vacuum check valve	Replace the check valve
	Collapsed vacuum hose	Replace the vacuum hose
	No vacuum to the vacuum hose	Connect the hose to a good vacuum source
	Bad power booster	Replace the booster
<b>Pedal Too Hard</b>	Vacuum booster not working	<i>See chart above</i>
	Frozen wheel cylinder	Replace wheel cylinder
	Binding pedal linkage	Correct the pedal linkage
	Blocked brake hose/line	Replace the brake hose/line
	Undersized caliper piston	Use a caliper with a larger piston Use a master cylinder with a smaller piston
	Undersized wheel cylinder	Use a larger wheel cylinder Use a master cylinder with a smaller piston
	Misadjusted proportioning valve	Readjust the proportioning valve
	Vehicle too heavy for brake system	Upgrade the brake system
<b>Dragging Brakes</b>	Improperly adjusted parking brake	Adjust the parking brake
	Pre-loaded master cylinder	Adjust pedal assembly Adjust the push rod between the master cylinder and brake pedal Adjust the push rod between the booster and the master cylinder
	Pre-loaded power booster	Adjust pedal assembly Adjust the push rod between the booster and brake pedal
	Residual check valves	Use a lower pressure residual check valve Remove residual check valve
	Blocked brake hose/line	Replace the brake hose/line
	Caliper misaligned to rotor	Straighten caliper mounting bracket Shim the caliper mounting bracket Adjust wheel bearings Replace wheel bearings
	Drum shoes out of adjustment	Adjust the shoes

SYMPTOM	CAUSE	SOLUTION
<b>Brake Light on Dash is Lit</b> <i>(Unequal Pressure Between Front and Rear)</i>	Leaking hose/line	Replace leaking hose/line
	Bad flexible brake hoses	Replace the brake hoses
	Air in lines/aerated fluid	Bleed brake system Flush the brake fluid
	Leaking caliper/wheel cylinder	Replace the leaking caliper/wheel cylinder
	Drum shoes out of adjustment	Adjust the shoes
	Improperly adjusted parking brake	Adjust the parking brake
	Caliper misaligned to rotor	Straighten caliper mounting bracket Shim the caliper mounting bracket Adjust wheel bearings Replace wheel bearings
	Brake pad kick back	Adjust wheel bearings Replace wheel bearings Repair loose axle C-clip (rear disc only) Adjust the parking brake
	Drum shoes out of adjustment	Adjust the shoes
	Drum and shoe have different arch	Replace drums Replace shoes
<b>Parking Brake Not Working</b>	Improperly adjusted parking brake	Adjust the parking brake
	Broken parking brake cable	Replace the parking brake cable
<b>Brake Pulls to One Side</b>	Bad wheel alignment	Align the suspension
	Oil/fluid on brake friction	Replace pads/shoes Clean the brake friction surfaces
	Drum shoes out of adjustment	Adjust the shoes
	Improperly adjusted parking brake	Adjust the parking brake
	Blocked brake hose/line	Replace the brake hose/line
	Frozen wheel cylinder	Replace wheel cylinder
<b>Rear Brakes Lockup First</b>	Misadjusted proportioning valve	Readjust the proportioning valve
	No proportioning valve	Use a proportioning valve
	Proportioning valve not working	Replace the proportioning valve
	Front calipers pistons too small	Use a larger front caliper Use a smaller rear caliper/wheel cylinder
	Oil/fluid on front brake friction	Replace front pads/shoes Clean the brake friction surfaces
	Front drum shoes out of adjustment	Adjust the shoes
	Blocked front brake hose/line	Replace the brake hose/line
	Frozen front wheel cylinder	Replace wheel cylinder
	Front brakes overheated/faded	Improve the brake cooling Use a slotted and drilled rotor Use a higher temperature brake pad Use a larger brake rotor Use a larger caliper and pad
<b>Not Enough Rear Brake</b>	Misadjusted proportioning valve	Readjust the proportioning valve
	Proportioning valve not working	Replace the proportioning valve
	Oil/fluid on rear brake friction	Replace front pads/shoes Clean the brake friction surfaces
	Rear drum shoes out of adjustment	Adjust the shoes
	Blocked rear brake hose/line	Replace the brake hose/line
	Frozen rear wheel cylinder	Replace wheel cylinder
	Rear brakes overheated/faded	Improve the brake cooling Use a slotted and drilled rotor Use a higher temperature brake pad Use a larger brake rotor Use a larger caliper and pad

# POWER STEERING TECH TIPS

## **POWER STEERING FLUID**

Always use the correct type of power steering fluid that is recommended by the manufacture. If you have components from several different manufactures it is important that the fluid used is compatible with all the components. Most high quality fluids will list the manufactures that their fluid is compatible with on their label.

## **VIBRATIONS IN THE STEERING WHEEL AND COLUMN**

In some installations the steering wheel or column could vibrate while the car is being driven. When ever possible, use a rag joint to connect the steering box or rack and pinion to the steering shaft. If there is not enough space for a rag joint you may be able to use a smaller diameter vibration damper. The diameter of these dampers is only slightly larger than a steering shaft coupler, but a couple of inches longer than a rag joint.

## **PRESSURE REDUCTION**

It is highly unlikely that you will need to reduce the pump pressure. Reducing the pressure will not make the steering less sensitive. It may make the car more difficult to steer at low (parking lot) speeds or when stopped. A better way to make the steering less sensitive, or require more effort at driving speeds is to increase the caster. Caster makes the steering wheel return to center, and increases the steering wheel effort. Most manual steering cars use about 1 degree positive caster, while most power steering systems work well between 3.5 and 7 of degrees positive caster.

## **REMOTE RESERVOIR SYSTEMS**

When using a remote reservoir, always mount the reservoir higher than the pump, and as close as possible to the pump. Long hoses and a low mounted reservoir can reduce the fluid flow to the pump causing the fluid to cavitate. Cavitation will not allow the pump to create pressure, and causes the pump to wear at a faster rate. Always use the largest size hose possible between the reservoir and the pump.

## **CONNECTING THE STEERING SHAFTS**

1. Determine whether you will need a two or three U-joint system. This is dictated by the angle between the shafts. We recommend up to 15° per U-joint for the optimum system, however up to 30° is acceptable. A support bearing will needed if you are using more than 2 U-joints.

2. Select the type of couplers, or U-joints and shaft that will be needed. The Application Guide list the most common shaft sizes used on steering boxes and rack and pinions. If the Application Guide does not list your application, then measure the diameter of the shaft and count the number of splines. If there is a section without splines, count the number of splines that go half way around the shaft and multiply by 2 to determine the correct spline count. Some shafts do not use splines; instead they have 2 large flats. These are known as DD shaft. They are usually 3/4" DD or 1" DD.
3. Measure the length of steering shafts that you will need to connect the column to the steering box or rack and pinion. It may be necessary to order the shaft longer than you need and adjust the shaft length after you install the couplers or U-joints on the column and steering box/rack and pinion.
4. Connect all of the shafts and couplers. Turn the steering wheel back and forth to the ends of the steering travel, checking to see if any of the shafts, U-joints, or other parts of the steering system can bind; make any changes needed to get a smooth steering movement. Also make certain that all of the U-joints are phased correctly.
5. Were any set screws are used you will need to make a small indentation were the set screw contacts the steering shaft. Simply the set screws one at time use a drill bit that is just small enough to not damage the threads in the U-joint, and drill a very shallow hole. This hole should be just deep enough to prevent the U-joint from coming off the shaft if the set screw were to come loose. Re-install the set screw and start this process over at the next set screw.

## **FASTENERS**

All bolt and nut fasteners are important attaching parts in that they can affect the performance of vital components. If replacement of these fasteners becomes necessary, style, type, quality and grade **MUST** be equivalent to OEM. **DO NOT** use a lesser substitute. Torque values must be maintained during assembly to assure proper retention of vital components.

## **NEW VS. USED VS. REBUILT**

Purchasing used is gambling, especially when you don't know the history of the source vehicle. When you connect a power steering pump to a rack or gear, you are instantly contaminating one with the other. The fluid can flow 8 to 10 quarts per minute and at that volume, it doesn't take long for the contaminated fluid from one unit to infect the other. So, now your choices are new or rebuilt. In many cases, new is no longer

available and in some cases a new unit may never have been tested. When purchasing from CPP, all of our units are 100% tested.

### **GETTING IT UP AND RUNNING**

Building a street rod or other specialty vehicle requires a different start up procedure than just replacing a worn out unit. Power steering systems are self bleeding, but we must help them a little along the way. It is preferred that the power steering system be the last to get going. This is because you will have your hands plenty busy firing up a fresh engine. After everything is working fine and all your adjustments completed, now is the time to hook up the power steering pump belt

### **V-BELT SYSTEMS**

1. Fill the system with your high quality fluid and let it set undisturbed for a few minutes while you recheck your work. Leave the reservoir cap off. Use this time to wipe the components off in preparation for leak check and visually inspect the hose routing, belt alignment and attaching hardware.
2. After your inspection, raise the front wheels off the ground and support the vehicle. Without starting the engine, slowly begin to cycle the steering wheel. The key here is "slowly"; about one revolution per 8-10 seconds. Continue to top off the fluid level

at the reservoir. When the level remains steady, inspect for leaks and start the engine.

3. Check the fluid level and inspect for leaks. Some vane type pumps require 1000 RPM or more to take the fluid down. Slowly cycle the steering wheel in both directions, lightly contacting the wheel stops. Continue to check the fluid level and add if necessary. If the pump begins to get noisy, turn the engine off and let the system set for 15 minutes. Air in the system will cause the pump to growl and the fluid level may rise when the engine is turned off.
4. Repeat the above steps until the system is operating normally. If air is still a problem after several rest periods, it may be that air is entering the system faster that it can be expelled at the reservoir fill. Look for leaks. Even the smallest of fluid leaks can be a source of massive amounts of air entering the system.
5. Always test drive the vehicle, making sure it is safe.

### **SERPENTINE SYSTEMS**

Obviously, the serpentine system does not allow for engine startup prior to power steering startup. Therefore, follow all of the above steps and take special precaution on step #2.

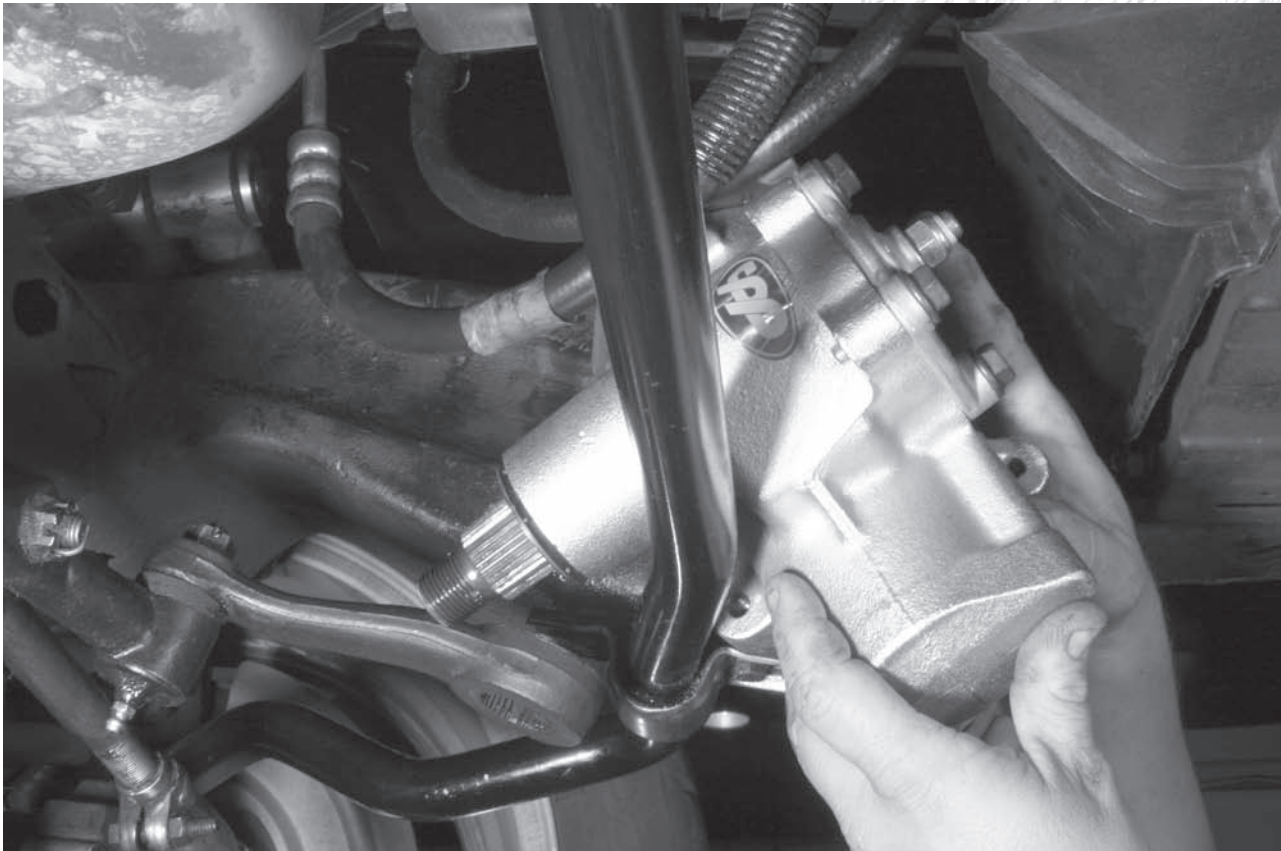

**COMMON FITTING SIZES**

Listed below are some of the more common power steering fitting sizes. There are many others not listed. If you are unsure about which fitting you need, give us a call.

	<b>PRESSURE</b>	<b>RETURN</b>
<b>GM Metric Pump</b>	16mm (M16-1.5) O-ring	Push / Clamp
<b>GM SAE Pump</b>	3/8 tube size (5/8-18 inverted flare)	Push / Clamp
<b>GM Rack &amp; Pinion / GM Metric Gear</b>	18mm (M18-1.5) O-ring	16mm (M16-1.5) O-ring
<b>GM SAE Gear</b>	7/16 tube size (11/16-18 inverted flare)	3/8 tube size (5/8-18 inverted flare)
<b>Ford Mustang II R&amp;P 1974 thru 7-5-77</b>	5/16 tube size (1/2-20 inverted flare)	3/8 tube size (5/8-18 inverted flare)
<b>Ford Mustang II R&amp;P 7-6-77 thru 1978</b>	5/16 tube size (1/2-20 inverted flare)	3/8 tube size (5/8-18) O-ring
<b>Ford T-Bird Rack &amp; Pinion thru 1988</b>	5/16 tube size (9/16-18 inverted flare)	3/8 tube size (5/8-18) O-ring
<b>Dodge Omni Rack &amp; Pinion</b>	18mm (M18-1.5) O-ring	16mm (M16-1.5) O-ring
<b>Mopar Gear with Fitting thru 1971</b>	1/4 or 5/16 male (1/2-20) inverted flare	Push / Clamp at Nozzle
<b>Mopar Gear without Fitting from 1972</b>	5/16 female tube size (1/2-20) O-ring	Push / Clamp at Nozzle

**\*\* Although we encourage our customers to use inverted flare fittings, there are other methods of sealing off hoses. In any case, avoid the use of pipe or thread dope or Teflon tape. These products can get into the hydraulic system and do substantial damage.**

<b>Common Torque Specifications</b>	
<b>Inverted flare fittings:</b>	25-34 foot pounds
<b>O-ring beaded hoses:</b>	20 foot pounds
<b>Teflon ringed hose fittings:</b>	14-20 foot pounds
<b>Mustang R&amp;P to crossmember:</b>	80-100 foot pounds
<b>Ford R&amp;P to crossmember:</b>	41-54 foot pounds
<b>Gear to frame mounting bolts:</b>	60-65 foot pounds
<b>Pitman arm to sector nut:</b>	235-250 foot pounds
<b>Pump keyway style pulley:</b>	60 foot pounds

**Rack & Pinion Pump Diagram**

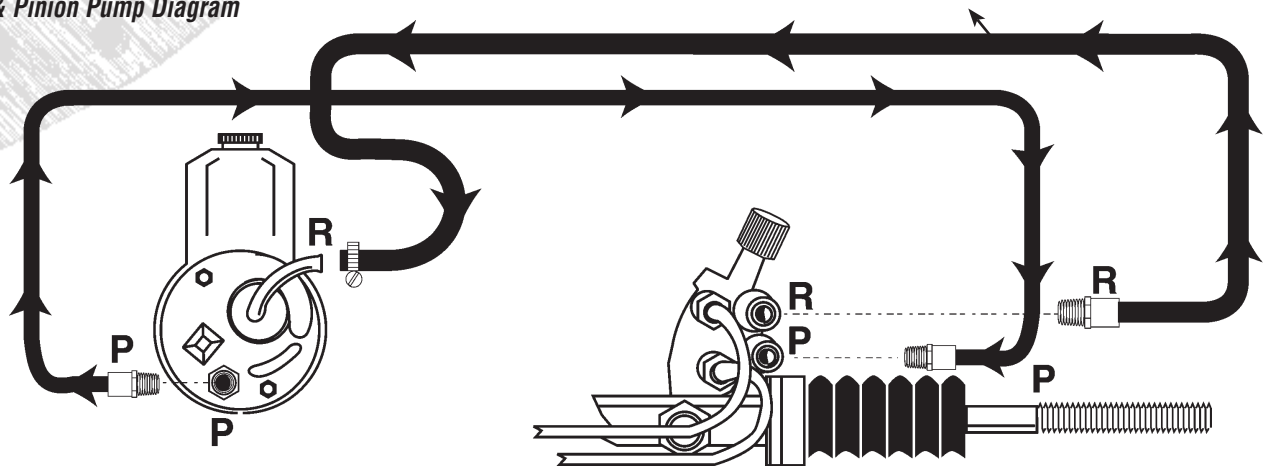

STEERING BOXES & RACKS SPLINE SIZES			
APPLICATION	SIZES	SPLINE DIA.	SPLINES
Ford Rack			
Mustang II & Pinto Manual	9/16"-26	.563	26
Mustang II & Pinto Power	3/4"-36	.750	36
Ford Box			
Manual & Power	3/4"-36	.750	36
GM Box Manual			
Vega	5/8"-36	.625	36
Corvette (1963-67)	3/4"-36	.750	36
Corvette (1968-83)	3/4"-30	.750	30
Model 122 (1965-85)	3/4"-30	.750	36
	3/4"-36	.750	36
Model 525 (1986-Present)	3/4"-30	.750	30
GM Box Power			
Model 605 (1978-84)	3/4"-30	.625	30
Model 800 (1977-Prior)	13/16"-36	.813	36
Model 800 (1978-Present)	3/4"-30	.750	30
GM Rack			
1979-Present	5/8"-36	.625	36
Variations	3/4"-30	.750	30
Corvette (1984-Present)	17mm DD	.670	570
Fiero 1	17mm DD	.670	570
Chrysler Box or Rack			
Chrysler - Omni Manual	9/16"-36	.563	26
Chrysler - Omni Power	9/16"-36	.563	36
Chrysler - Volar	9/4"-30	.750	36
Chrysler	5/8"-36	.625	36
Chrysler	3/4"-36	.750	36
Chrysler	13/16"-36	.813	36

STEERING COLUMNS SPLINE SIZES			
APPLICATION	SIZES	SPLINE DIA.	SPLINES
GM Column			
Small Spline	3/4"-36	.750	36
Large Spline	1"-48	1.00	48
Small DD	3/4"-DD	.750	DD
Large DD	1"-DD	1.00	DD

**DETERMINING SPLINE SIZE**

To determine the spline size of a component (rack and pinion, steering column and steering box), measure the outside diameter and count the number of splines. If there is a flat spot on the shaft and some of the splines are missing, count halfway around where there are splines and double that number. We need to know how many teeth are in a theoretical full circle.

Available U-joint Combinations are: A) Smooth Bore on both ends; B) Smooth Bore and Spline or Double D; C) Spline and/or Double D on each end.

COUNT SPLINES TO CENTER LINE  
MULTIPLY BY TWO

Double D (DD) Splined (SP) Smooth (S)

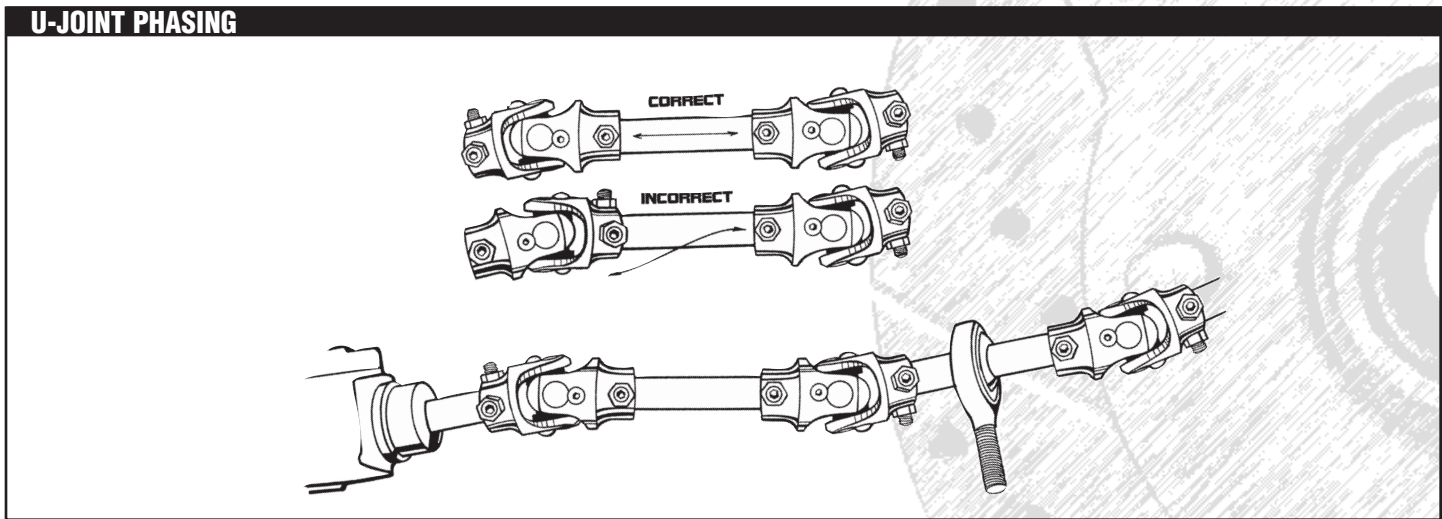

**GENERAL TORQUE SPECIFICATIONS:**

1/4"	grade 5	10lb/ft	1/4"	grade 8	14lb/ft
5/16"	grade 5	19lb/ft	5/16"	grade 8	29lb/ft
3/8"	grade 5	33lb/ft	3/8"	grade 8	47lb/ft
7/16"	grade 5	54lb/ft	7/16"	grade 8	78lb/ft
1/2"	grade 5	78lb/ft	1/2"	grade 8	119lb/ft
9/16"	grade 5	114lb/ft	9/16"	grade 8	169lb/ft
5/8"	grade 5	154lb/ft	5/8"	grade 8	230lb/ft



*Classic Performance Products, Inc.*

175 E. Freedom Avenue, Anaheim CA 92801  
714.522.2000 | [www.classicperform.com](http://www.classicperform.com)